

**D-SERIES CRAWLER EXCAVATORS
CX130D | CX160D | CX180D**

CASE

CONSTRUCTION



**TIER 4
FINAL
EU STAGE IV**

**IT'S TIME
FOR MORE**

www.casece.com

**EXPERTS FOR THE REAL WORLD
SINCE 1842**

HERITAGE

A TRADITION OF INDUSTRY FIRSTS



EXPERTS FOR THE REAL WORLD

SINCE 1842

1842 CASE is founded.

1869 The first CASE portable steam engine - road construction is born.

1957 The first factory - integrated loader/backhoe in the world: a CASE industry first.

1969 CASE begins skid steer loader production.

1992 Sumitomo becomes supplier to CASE Corporation distributing excavators ranging from 7 to 80 tons.

1998 Global Alliance signed between CASE Corporation and Sumitomo.

2001 CASE introduces the first of its CX excavators, powerful new "thinking machines" designed to enhance productivity through onboard intelligence features.

2007 CX210B is awarded the «Good Design Award» by the design Academy of Japan.

2008 CX210B wins the 18th «Energy Conservation Award» from the

Agency for Natural Resources and Energy of the Japanese Ministry of Economy.

2011 CASE becomes the first construction equipment manufacturer to offer both selective catalytic reduction and cooled exhaust gas recirculation as solutions to meet stringent emissions standards.

2015 CASE launches the new "D series" Tier 4 final/ EU Stage IV Crawler Excavators.

CRAWLER EXCAVATORS D-NA BUILT TO LAST AND CONTROL



HIGH RELIABILITY

Improved D-esign for D-urable performances

- The boom and arm have been re-designed according to the latest stress analysis criteria to reduce stress points while maintaining weight optimization to ensure the best lifting performance.
- The optimized shape of the flange reduces stress concentration at the welded part.
- The undercarriage has been re-designed and re-shaped to facilitate the welding process, enhancing the reliability of the fabricated structures.
- The One-Side-Slope lower frame design reduces the time needed to clean the undercarriage.
- The thickness of the structural plates has been increased, especially in those parts where a high level of protection is required for components.

HIGH QUALITY

Accurate, simple and robust design for high durability

- True to CASE's enviable reputation for reliability and durability, the D-Series delivers leading design solutions and manufacturing quality.
- Wide choice of arm solutions, including the heavy- duty arm with reinforcement plate and bars on the bottom side.



HIGH PRECISION AND CONTROLLABILITY

Smooth control with the CASE Intelligent Hydraulic System

The proven CASE Intelligent Hydraulic System (CIHS) delivers impressive machine control with unrivalled energy savings in all cycle time phases (digging, boom up and swing, dumping).

D-SERIES CRAWLER EXCAVATORS



HIGH VERSATILITY

Working modes easily adapt to every work load

The familiar working mode systems offers 3 power modes to match different customer needs.

- A** MODE for grading, lifting and precision work.
- H** MODE the best balance between productivity and fuel economy.
- SP** MODE extra speed and power for the most demanding jobs that require maximum productivity.

Auto Power boost automatically increases hydraulic pressure according to the operation's demands.



FAST CYCLES

High performance hydraulics control

- The new electrically controlled pumps delivers faster cycle times.
- Oil flow can be adjusted according to working needs, or increased smoothly while starting travel and boom down.
- As a result, the machine responsiveness to operation load is multiplied, resulting in cycle times up to 5% faster than the previous generation.

PRODUCTIVITY

IT'S TIME FOR BIGGER PERFORMANCE



HIGH EFFICIENCY

Great performances with low fuel consumption

CASE advanced energy management provides solid fuel saving opportunities and lower emissions, and helps to prolong the life of the machine. It consists of 5 Energy Saving controls:

- Torque control decreases main pump loads to prevent a drop in engine rpm, with improved sensitivity to control/monitor main pump loads
- Boom Economy Control (BEC) Increased fuel efficiency during boom lower and swing operations, like dump unloading
- Swing Relief Control (SWC) Carefully manages the hydraulic power distribution in slewing operations to deliver the most efficient flow and pressure.
- Spool Stroke Control (SSC) Creates an automatic pressure adjustment during digging and leveling operations.
- Idle functions: the Auto Idle function lowers engine rpm after 5 seconds of lever inactivity whatever the throttle position, while the Idle Shutdown function shuts the engine down after a pre-set time. Both are manually switchable.



CLEAN AND MAINTENANCE-FREE POWER

EU Stage IV/TIER4 Final compliant CASE engines

- Maintenance-free SCR and DOC-only solution
- No Diesel Particulate Filter (DPF) or regeneration are required as no solid particles remain trapped into the system, resulting in maximum uptime and lower operating costs.
- High engine efficiency of the latest generation, electronically controlled, high pressure common rail with multi-injection engine ensures great performances and low fuel consumption.
- CASE adds a variable geometry turbo charger to increase exhaust gas recirculation efficiency without losing power.
- The system is also very economical in its use of AdBlue, which is just 2.5%- 3% of fuel consumption. The large AdBlue tank only needs to be refilled every 10 fuel refills, so that no time is wasted.

D-SERIES CRAWLER EXCAVATORS



COMFORTABLE AND SAFE CAB

The ultimate interior cab configuration

- Superior cab structure with ample legroom for the operator.
- Fully adjustable workstation
- New ergonomically designed highback seat with air -suspension for excellent comfort.
- Optional seat tilting adjustment and seat heater.
- Top class features include 178 mm colour LED Monitor, bluetooth tuner and Radio, spacious storage compartment, 12v accessory plug, clipboard holder, mobile phone holder, warm and cool box, fuse box service connection, storage tray and ergonomic arm rest.



SMOOTH RIDE, QUIET WORK ENVIRONMENT

Soundproof pressurised cab

- The cushioning system lowers noise and vibration levels for the operator's ultimate comfort.



COMFORT RULES FIRST CLASS CAB AND SEAT



D-SERIES CRAWLER EXCAVATORS



SAFE OPERATION

ROPS cab and FOPS level II

A safe working environment for the operator:

- Reinforced structure of the cab compliant with ROPS/FOPS requirements.
- Standard head protection approved to FOPS Level 2.
- Wide offering of optional front guards.
- Optional factory fitted travel alarm for greater safety on the jobsite around the machine.



OUTSTANDING VISIBILITY

Safety-minded cab structure

Cab designed to create a perceptibly safe and secure working environment:

- Ample glazed surface.
- Rear and side view camera.
- Unique 178 mm LED monitor with continuous camera view.
- Efficient use of space with grouped engine, cooling and after-treatment systems to provide excellent rear visibility.
- Optional LED lighting package provides a deeper and wider visibility coverage of the area around the machine when working after dark.



SAFETY AND MAINTENANCE

WORK SAFELY IN ALL CONDITIONS



SAFE ACCESS TO UPPERCARRIAGE

Solid and robust platform and handrails

- Wide, robust and comfortable steps for safe access to the top of the hood.
- Solid handrail for protection on the top of the hood.
- Non slip-plates and top hood cover are supported by 2 gas pistons and secured by 2 mechanical stops when open.



EASY MAINTENANCE

CASE stays «grounded»

- All filters and regular fill points are grouped for easy access.
- Engine oil change intervals set at 500 hours.
- Radiator and cooler cores mounted side by side for easy access for cleaning and more efficient cooling. Dust-proof net in front of the radiators is accessible from the ground
- Standard 100 l/min refueling pump with automatic cut off reduces downtime for regular fills.
- Optional hydraulic and engine oil sampling port accessible at ground level for easy oil check.
- Battery Shutdown Switch for safe maintenance on the electrical system.
- All the D-series crawler excavators feature the Extended Maintenance System (EMS) bushings, providing 1,000 hour greasing intervals on all pins except the attachment linkage.



MAIN REASONS TO CHOOSE THE D-SERIES



HIGH PRECISION AND CONTROLLABILITY

CASE Intelligent Hydraulic System (CIHS):
synonymous with high performance smooth
control.



HIGH RELIABILITY

Reliability and durability with the new
redesigned arm, boom and undercarriage.



HIGH VERSATILITY

- 3 available power modes to match
customer needs (A, H, SP)
- Auto Power boost job-sensing
hydraulic pressure increase.



HIGH EFFICIENCY

- Energy saving system to take advantage
of all fuel saving opportunities: up to 8% more fuel efficiency
- High levels of AdBlue autonomy with larger
AdBlue tank and low additive consumption





5% FASTER

- New electronically controlled hydraulic pumps



OUTSTANDING VISIBILITY

- Wide glazed area
- Rear and side view cameras
- Large LED monitor
- Optional LED lighting package



SMOOTH RIDE, QUIET WORK ENVIRONMENT

- Cab with cushioning system
- Low noise and vibration



COMFORTABLE AND SAFE CAB

- Extra spacious cab
- Fully adjustable workstation
- New high back seat



LOW EMISSIONS

- EU Stage IV/Tier4 final compliant
- No DPF
- DOC and SCR-only maintenance-free components



SAFE OPERATION AND MAINTENANCE

- ROPS cab and FOPS level II
- Standard extended handrails and guardrails
- Optional factory fitted travel alarm
- Maintenance points grouped for easy and safe access





THE SCIENCE BIT

The Case SiteWatch telematics system uses a high-tech control unit mounted on each machine to collate information from that machine and from GPS satellites. This data is then sent wirelessly through the mobile communication networks to the Case Telematics Web Portal.



SiteWatch: centralised fleet control benefits at your fingertips

Measure your true asset availability and optimise it

- Eliminate the “phantom fleet”: SiteWatch allows to identify spare units or under loaded machines on each site.
- Become able to reallocate units where they are more needed.
- Forward Maintenance Planning is easier since the actualised working hours are always available.
- Extend the benefits of SiteWatch to the rest of your fleet: SiteWatch can be installed on the units of other brands as well.

Challenge your Total Cost of Ownership!

- Being able to compare the fuel usage of different machine types will allow you choose the right equipment.
- Save on transport costs with planned and grouped maintenance tasks.
- Peace of mind, optimised uptime and lower repair costs: with preventive maintenance you can for example be alerted if the engine needs to be serviced and avoid a disruptive breakdown.
- Be able to compare your asset Return On Investment on different sites.
- Your equipment is used only during working hours. You can set up alerts so that you know if it is in use during the weekend or at night.
- Integrate with the programmed maintenance package, so that you can be sure every machine is at the right place at the right time.

More Safety, Lower Insurance Premium

- Keep thieves away: dissuade them from attacking your asset because it is geo-localised. SiteWatch is hidden so that thieves can't find it quickly.
- Your fleet is used only where you decide. You can define a virtual fence and receive an email when a machine exits that perimeter.

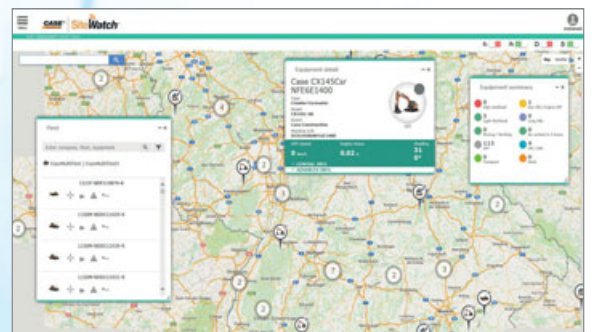

STANDARD AND OPTIONS

STANDARD EQUIPMENT

ENGINE

Isuzu 4-cylinder turbo-charged diesel
Tier 4 Final/EU stage IV Certified
Selective Catalytic Reduction (SCR)
Diesel Oxidation Catalyst (DOC)
Cooled Exhaust Gas Recirculation (CEGR)
VGT turbocharger
Electronic fuel injection
High pressure common rail system
Neutral safety start
Auto-engine warm up, emergency stop
Glow-plug pre-heat
Engine Protection Feature (EPF)
Dual-stage fuel filtration
Dual element air filter
Remote oil filter
Green plug oil drain
500-hour engine oil change interval
24-Volt system
Battery disconnect switch
High ambient temperature cooling package
External Fuel and AdBlue gauges
Fuel cooler
Fuel filter restriction indicator
Fuel shut-off valve
Idle start
Radiator, oil cooler, intercooler - protective Screen
Refueling Pump

FUEL ECONOMY SYSTEMS

Engine Idle/Fuel Economy System:
Auto-idle
One-touch idle
Auto-idle shut-down
Torque control
Boom Economy Control (BEC)
Swing Relief Control (SWC)
Spool Stroke Control (SSC)

OPTIONAL EQUIPMENT

HYDRAULICS

Clamshell circuit
Low-flow circuit, proportional control
Single acting pedal activated hammer circuit
Single acting hammer circuit with electrical proportional control
Pedal activated multifunction (hammer/high flow) circuit
Multifunction (hammer/high flow) circuit with electrical proportional control

ATTACHMENTS

CX130D

HD arm 2.1 m
Arm 3.0 m

HYDRAULICS

Electronically controlled hydraulic pumps
Auto power boost
Auto travel speed change
Selectable work modes
Overload warning device
ISO pattern controls
Pre-set auxiliary pump settings
Switch controlled auxiliary selection
Auxiliary valve
Hydraulic filter restriction indicator
Oil cooler
5,000 hour hydraulic oil change interval
2,000 hour hydraulic filter change interval

UPPERSTRUCTURE

ISO mirrors
Handrail - RH access
ISO guard rails
Isolation mounted cab (fluid and spring)
Lockable fuel cap, service doors and toolbox
Rear and side view safety camera

OPERATOR STATION

ROPS protection
FOPS guard OPG level II
Pressurized cab
Tempered safety glass
One-touch lock front window
Sun visor&rain deflector
AC/heat/defrost w/auto climate control
Hot&coolbox, cup holder & ashtray
Interior dome light
Cloth covered air-suspension high-back seat
Sliding seat - 90 mm
Seat-belt
Adjustable armrests
Tilting consoles - 4-position
Low-effort joystick controls
Sliding cockpit 180 mm

CX160D-CX180D

Arm 2.2 m
Arm 3.0 m
Hydraulic quick coupler provision
Safety valves and bucket linkage with hook

OPERATOR STATION

Front cab guard - vertical bars (OPG level 2)
Front cab guard - vertical bars (OPG level 1)
Front mesh screen
Travel alarm
AM/FM CD/radio with antenna and 2-speakers
LED working lights
Side view camera
Side view camera with LED lights (right and left)

Auxiliary select system
Aux-in port for personal electronics
Multifunction LED color monitor (180 mm)
26 selectable languages for monitor
Anti-theft system (start code system)
Rubber floor mat
12-volt electric socket
24-volt cigarette lighter
One-piece right hand window
Working lights (boom&upperstructure)
Cab top working lights
Windshield wiper / washer
Clear (Lexan) roof window w/sunshade
Storage compartments
On-board diagnostic system
Torque control

ATTACHMENTS

CX130D

Standard monoboom 4.63 m
Arm 2.50 m

CX160D - 180D

Standard monoboom 5.15 m
Arm 2.6 m
Boom mounted work light
Auxiliary pipe brackets
Centralized lube bank
Attachment cushion valve

UNDERCARRIAGE

600 mm steel triple grouser shoes
Lashing points
Single track guide (CX160D, CX180D)

UNDERCARRIAGE

500 mm steel triple grouser shoes (CX130DLC, CX130D Blade and CX160D)
700 mm steel triple grouser shoes
800 mm steel triple grouser shoes (CX180D)
500 mm rubber link chains (CX130D Blade)
Double track guide (CX130D)
Triple track guide (CX160D, CX180D)

TELEMATICS

Three years SiteWatch "Advanced" subscription with remote monitoring and one user's licence

CX D-SERIES

CX130D

ENGINE

Model _____ ISUZU AR-4JJ1X
 Type _____ Water-cooled, 4-cycle diesel, 4-cylinder in line,
 High pressure common rail system (electric control),
 turbocharger with air cooled intercooler, SCR system

Emissions _____ Tier 4 final / Eu stage IV
 Number of cylinders/Displacement (l) _____ 4 / 2.99
 Bore and stroke (mm) _____ 95.4 X 104.9

Rated flywheel horse power

SAE J1349, ISO 9249 _____ 76.4 kW / 102 hp at 2000 min⁻¹
 ISO 14396 _____ 78.5 kW / 105 hp at 2000 min⁻¹

Maximum torque

SAE J1349, ISO 9249 _____ 349 Nm at 1800 min⁻¹
 ISO 14396 _____ 356 Nm at 1800 min⁻¹

HYDRAULIC SYSTEM

Main pumps _____ 2 variable displacement axial piston pumps
 with regulating system

Max. oil flow (l/min) _____ 2 × 129 at 2000 min⁻¹

Working circuit pressure

Boom/Arm/Bucket (MPa) _____ 34.3
 36.3 with auto power boost

Swing circuit (MPa) _____ 27.9

Travel circuit (MPa) _____ 34.3

Pilot pump _____ 1 gear pump

Max. oil flow (l/min) _____ 20

Working circuit pressure (MPa) _____ 3.9

Blade pump (CX130D Blade) _____ 1 gear pump

Max. oil flow (l/min) _____ 54 at 2000 min⁻¹

Working circuit pressure (MPa) _____ 20.6

Boom Cylinders

Bore (mm) _____ 105

Stroke (mm) _____ 961

Arm Cylinders

Bore (mm) _____ 115

Stroke (mm) _____ 1108

Bucket Cylinders

Bore (mm) _____ 95

Stroke (mm) _____ 881

SWING

Swing Motor _____ Fixed displacement axial piston motor

Maximum swing speed (min⁻¹) _____ 14.3

Swing torque (Nm) _____ 33.000

FILTERS

Suction filter (µm) _____ 105

Return filter (µm) _____ 6

Pilot line filter (µm) _____ 8

ELECTRICAL SYSTEM

Voltage (V) _____ 24

Alternator (Amp) _____ 50

Starter (V/kW) _____ 24/4.0

Battery _____ 2 X 12 V 72 Ah/5HR

UNDERCARRIAGE

Travel motor _____ Variable displacement axial piston motor

Travel speeds

High (km/h) _____ 5.6

Low (km/h) _____ 3.4

Automatic travel speed shifting

Drawbar pull (kN) _____ 116

CX130D BLADE

Number of carrier rollers (each side) _____ 1

Number of track rollers (each side) _____ 7

Number of shoes (each side) _____ 43

CX130D LC

Number of carrier rollers (each side) _____ 2

Number of track rollers (each side) _____ 7

Number of shoes (each side) _____ 46

CIRCUIT AND COMPONENT CAPACITIES

Fuel tank (l) _____ 260

Hydraulic system (l) _____ 157

Hydraulic tank (l) _____ 82

Adblue tank (l) _____ 75

SOUND LEVEL

External guaranteed sound level

(EU Directive 2000/14/EC) _____ LwA 99 dB(A)

Operator cab sound pressure level (ISO 6396) _____ LpA 69 dB(A)

WEIGHT AND GROUND PRESSURE

with 2.50 m Arm , 0.5 m³ Bucket , 600 mm grouser shoes, operator,
 lubricant, coolant, full fuel tank and FOPS protection level 2

	CX130D	BLADE	LC
Weight		14.000 kg	13.400 kg
Ground Pressure		0.038 MPa	0.033 MPa
Counterweight		1.990 kg	

SPECIFICATIONS

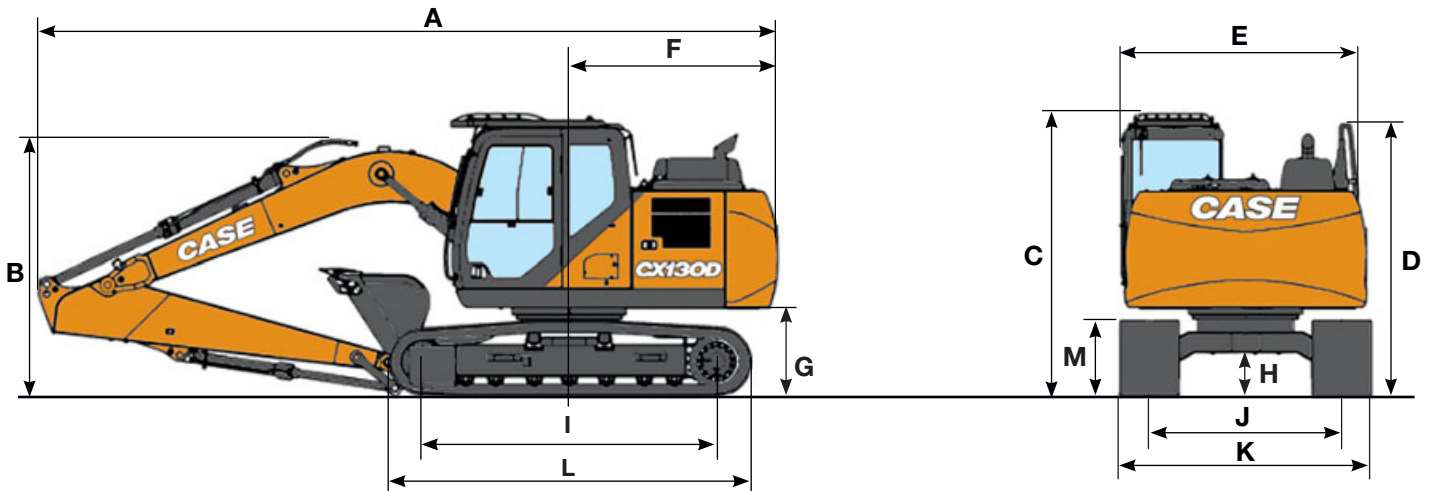

GENERAL DIMENSIONS

	mm	BLADE			LC		
		Arm 2.50 m	Arm 3.0 m	Arm 2.10 m	Arm 2.50 m	Arm 3.0 m	Arm 2.10 m
Overall length (without attachment)	mm	4160	4160	4160	4030	4030	4030
A Overall length (with attachment)	mm	7900	7900	7890	7650	7640	7640
B Overall height (to top of boom)	mm	2770	2640	2680	2770	2640	2680
C Cab height	mm	2920	2920	2920	2920	2920	2920
D Overall height (to top of handrail)	mm	2810	2810	2810	2810	2810	2810
E Upper structure overall width	mm	2530	2530	2530	2530	2530	2530
F Swing (rear end) radius	mm	2170	2170	2170	2170	2170	2170
G Clearance height under upper structure	mm	895	895	895	895	895	895
H Minimum ground clearance	mm	425	425	425	420	420	420
I Wheel base (Center to center of wheels)	mm	2790	2790	2790	3040	3040	3040
L Crawler overall length	mm	3500	3500	3500	3760	3760	3760
M Crawler tracks height	mm	780	780	780	780	780	780
J Track gauge	mm	1990	1990	1990	1990	1990	1990
K Undercarriage overall width (with 600 mm shoes)	mm	2590	2590	2590	2590	2590	2590

PERFORMANCE DATA

		Arm 2.50 m	Arm 3.0 m	Arm 2.10 m
Boom length	mm	4630	4630	4630
Bucket radius	mm	1200	1200	1200
Bucket wrist action	°	178	178	178
A Maximum reach at GRP	mm	8170	8640	7810
B Maximum reach	mm	8310	8770	7960
C Max. digging depth	mm	5550	6050	5160
D Max. digging height	mm	8770	9050	8550
E Max. dumping height	mm	6390	6680	6170
F Min. swing radius	mm	2340	2660	2360

DIGGING FORCE (ISO 6015)

		Arm 2.50 m	Arm 3.0 m	Arm 2.10 m
Arm digging force	kN	62	56	70
with Auto power up	kN	66	60	74
Bucket digging force	kN	90	90	90
with Auto power up	kN	95	95	95

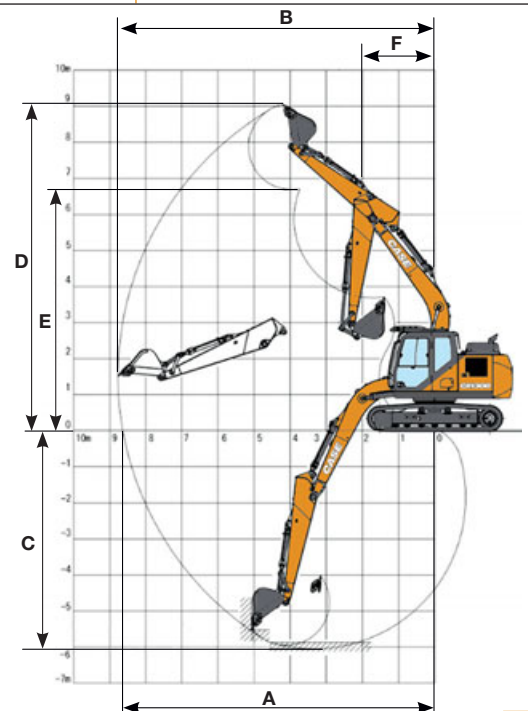

LIFTING CAPACITY

CX130D



BLADE DOWN - 2.50 m length, 600 mm shoes. Max reach 7.11 m

6.0 m							2200*	2200*	5.47
4.0 m			3880*	3880*	3550*	2580	2010*	2010*	6.65
2.0 m			5650*	4450	4050*	2470	2060*	1920	7.09
0 m			6930*	4140	4520*	2350	2330*	1930	6.94
-2.0 m	7160*	7160*	6850*	4070	4310*	2330	3070*	2260	6.15
-4.0 m			4820*	4230			4130*	3730	4.39

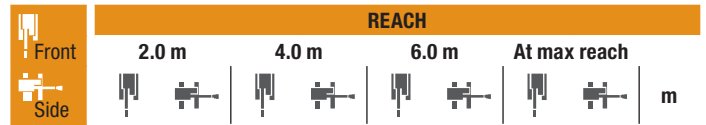

BLADE DOWN - 2.10 m length, 600 mm shoes. Max reach 6.76 m

6.0 m			3610*	3610*			2730*	2730*	5.0
4.0 m			4270*	4270*	3800*	2530	2440*	2340	6.27
2.0 m			5980*	4350	4200*	2420	2490*	2040	6.74
0 m			7000*	4080	4550*	2330	2840*	2050	6.58
-2.0 m	7910*	7910*	6630*	4060			3830*	2480	5.74

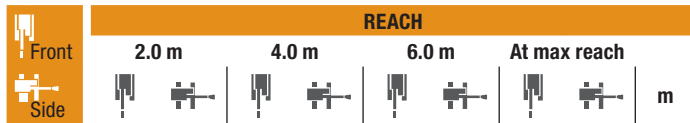

BLADE DOWN - 3.0 m length, 600 mm shoes. Max reach 7.57 m

6.0 m					2160*	2160*	1990*	1990*	6.06
4.0 m					3160*	2590	1850*	1850*	7.14
2.0 m			5060*	4480	3740*	2440	1900*	1700	7.55
0 m			6610*	4090	4330*	2300	2130*	1700	7.41
-2.0 m	6340*	6340*	6890*	3960	4410*	2240	2720*	1950	6.68
-4.0 m	10230*	10230*	5570*	4060			3960*	2890	5.11

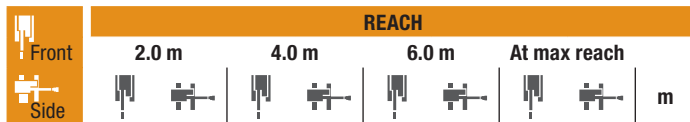

BLADE UP - 2.50 m length, 600 mm shoes. Max reach 7.11 m

6.0 m							2200*	2200*	5.47
4.0 m			3880*	3880*	3140	2430	2010*	2010*	6.65
2.0 m			5620	4150	3020	2310	2060*	1800	7.09
0 m			5280	2850	2900	2200	2330*	1800	6.94
-2.0 m	7160*	7160*	5210	3780	2870	2180	2780	2120	6.15
-4.0 m			4820*	3940			4130*	3480	4.39

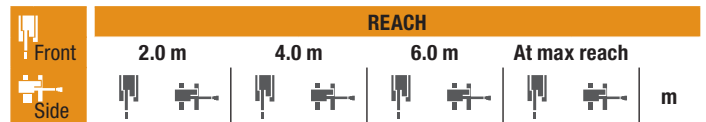

BLADE UP - 2.10 m length, 600 mm shoes. Max reach 6.76 m

6.0 m			3610*	3610*			2730*	2730*	5.0
4.0 m			4270*	4270*	3080	2370	2440*	2200	6.27
2.0 m			5520	4050	2970	2270	2490	1910	6.74
0 m			5220	3790	2870	2180	2520	1920	6.58
-2.0 m	7910*	7910*	5200	3770			3060	2320	5.74



BLADE UP - 3.0 m length, 600 mm shoes. Max reach 7.57 m

6.0 m					2160*	2160*	1990*	1990*	6.06
4.0 m					3150	2430	1850*	1800	7.14
2.0 m			5060*	4180	3000	2290	1900*	1590	7.55
0 m			5240	2800	2850	2150	2090	1590	7.41
-2.0 m	6340*	6340*	5090	3670	2780	2090	2410	1820	6.68
-4.0 m	10230*	10230*	5200	3770			3610	2700	5.11

* The above loads (kg) are compliant to the ISO standards and refer to the excavator equipped without bucket. The indicated loads are no more than 87% of hydraulic system lifting capacity or 75% of static tipping load. Values marked with an asterisk (*) are limited by the hydraulic lifting capacity.



LC - 2.50 m length, 600 mm shoes. Max reach 7.11 m

	2.0 m	4.0 m	6.0 m	At max reach	
6.0 m					2200* 2200* 5.47
4.0 m		3880*	3880*	3510 2320	2010* 1950 6.65
2.0 m		5650*	3970 3380	2210	2060* 1710 7.09
0 m		6070	3670 3260	2090	2330* 1710 6.94
-2.0 m	7160*	7160*	5990 3600	3240 2070	3070* 2010 6.15
-4.0 m		4820*	3760		4130* 3320 4.39



LC - 2.10 m length, 600 mm shoes. Max reach 6.76 m

	2.0 m	4.0 m	6.0 m	At max reach	
6.0 m		3610*	3610*		2730* 2730* 5.0
4.0 m		4270*	4270*	3450 2270	2440* 2100 6.27
2.0 m		5980*	3880 3340	2160	2490* 1810 6.74
0 m		6000	3610 3230	2070	2840* 1830 6.58
-2.0 m	7910*	7910*	5980 3590		3460 2200 5.74



LC - 3.0 m length, 600 mm shoes. Max reach 7.57 m

	2.0 m	4.0 m	6.0 m	At max reach	
6.0 m			2160*	2160*	1990* 1990* 6.06
4.0 m			3160*	2320	1850* 1720 7.14
2.0 m		5060*	4000 3370	2180	1900* 1510 7.55
0 m		6020	3620 3210	2040	2130* 1510 7.41
-2.0 m	6340*	6340*	5870 3490	3150 1980	2710 1730 6.68
-4.0 m	10230*	10230*	5570*	3590	3960* 2570 5.11

GENERAL PURPOSE BUCKET (DIRECT MOUNT)

CAPACITY (ISO7451 HEAPED)	WIDTH	WEIGHT	ARM 2.50 m	ARM 3.0 m	ARM 2.10 m
0.21 m ³	450 mm	249 kg	○	○	○
0.31 m ³	600 mm	283 kg	○	○	○
0.41 m ³	750 mm	326 kg	○	○	○
0.52 m ³	900 mm	359 kg	○	●	○
0.58 m ³	1000 mm	393 kg	●	■	○
0.66 m ³	1100 mm	425 kg	●	■	●
0.73 m ³	1200 mm	449 kg	■	×	■

GENERAL PURPOSE SCOOP BUCKET (WITH CASE MULTI-FIT S COUPLER)

CAPACITY (ISO7451 HEAPED)	WIDTH	WEIGHT	ARM 2.50 m	ARM 3.0 m	ARM 2.10 m
0.21 m ³	450 mm	242 kg	○	○	○
0.31 m ³	600 mm	277 kg	○	○	○
0.41 m ³	750 mm	311 kg	○	●	○
0.52 m ³	900 mm	355 kg	●	■	○
0.58 m ³	1000 mm	385 kg	■	■	●
0.66 m ³	1100 mm	418 kg	■	×	■
0.73 m ³	1200 mm	442 kg	×	×	■

TILTABLE DITCH CLEANING BUCKET

CAPACITY (ISO7451 HEAPED)	WIDTH	WEIGHT	ARM 2.50 m	ARM 3.0 m	ARM 2.10 m
0.46 m ³	1500 mm	634 kg	●	■	●
0.55 m ³	1800 mm	690 kg	■	×	■
0.61 m ³	2000 mm	729 kg	×	×	■

○ Rated material density up to 2 ton/m³ ● Rated material density up to 1.6 ton/m³ ■ Rated material density up to 1.2 ton/m³ × Not applicable

* The above loads (kg) are compliant to the ISO standards and refer to the excavator equipped without bucket. The indicated loads are no more than 87% of hydraulic system lift capacity or 75% of static tipping load. Values marked with an asterisk (*) are limited by the hydraulic lifting capacity.

CX D-SERIES

CX160D

ENGINE

Model _____ ISUZU AR-4JJ1X
 Type _____ Water-cooled, 4-cycle diesel, 4-cylinder in line,
 High pressure common rail system (electric control),
 turbocharger with air cooled intercooler, SCR system
 Emissions _____ Tier 4 Final / Eu stage IV
 Number of cylinders/Displacement (l) _____ 4 / 2.99
 Bore and stroke (mm) _____ 95.4 x 104.9

Rated flywheel horse power

SAE J1349, ISO 9249 _____ 83.2 kW / 111 hp at 2200 min⁻¹

ISO 14396 _____ 86 kW / 115 hp at 2200 min⁻¹

Maximum torque

SAE J1349, ISO 9249 _____ 349 Nm at 1800 min⁻¹

ISO 14396 _____ 356 Nm at 1800 min⁻¹

HYDRAULIC SYSTEM

Main pumps _____ 2 variable displacement axial piston pumps
 with regulating system

Max. oil flow (l/min) _____ 2 × 142 at 2200 min⁻¹

Working circuit pressure

Boom/Arm/Bucket (MPa) _____ 34.3

36.3 with auto power boost

Swing circuit (MPa) _____ 27.9

Travel circuit (MPa) _____ 34.3

Pilot pump _____ 1 gear pump

Max. oil flow (l/min) _____ 22

Working circuit pressure (MPa) _____ 3.9

Boom Cylinders

Bore (mm) _____ 115

Stroke (mm) _____ 1179

Arm Cylinders

Bore (mm) _____ 125

Stroke (mm) _____ 1280

Bucket Cylinders

Bore (mm) _____ 105

Stroke (mm) _____ 985

SWING

Swing Motor _____ Fixed displacement axial piston motor

Maximum swing speed (min⁻¹) _____ 11.5

Swing torque (Nm) _____ 45100

FILTERS

Suction filter (µm) _____ 105

Return filter (µm) _____ 6

Pilot line filter (µm) _____ 8

ELECTRICAL SYSTEM

Voltage (V) _____ 24

Alternator (Amp) _____ 50

Starter (V/kW) _____ 24/4.0

Battery _____ 2 X 12 V - 72 Ah/5HR

UNDERCARRIAGE

Travel motor _____ Variable displacement axial piston motor

Travel speeds

High (km/h - automatic travel speed shifting) _____ 5.4

Low (km/h) _____ 2.8

Drawbar pull (kN) _____ 160

Number of carrier rollers (each side) _____ 2

Number of track rollers (each side) _____ 7

Number of shoes (each side) _____ 44

CIRCUIT AND COMPONENT CAPACITIES

Fuel tank (l) _____ 300

Hydraulic system (l) _____ 167

Hydraulic tank (l) _____ 82

Adblue tank (l) _____ 85

SOUND LEVEL

External guaranteed sound level

(EU Directive 2000/14/EC) _____ LwA 100 dB(A)

Operator cab sound pressure level (ISO 6396) _____ LpA 69 dB(A)

WEIGHT AND GROUND PRESSURE

(with 2.62 m arm, 0.62 m³ bucket, 600 mm grouser shoes, operator,
 lubricant, coolant, full fuel tank and FOPS protection level 2)

CX160D

Weight _____ 17400 kg

Ground Pressure _____ 0.041 MPa

Counterweight _____ 2920 kg

SPECIFICATIONS

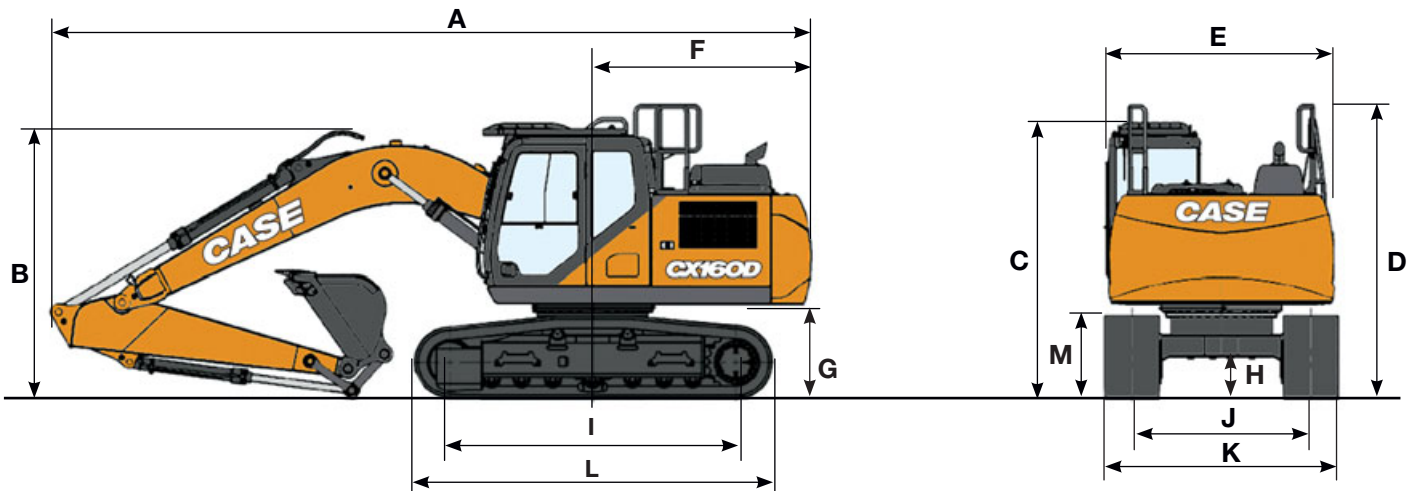

GENERAL DIMENSIONS

		Arm 2.6 m	Arm 3.0 m	Arm 2.2 m
Overall length (without attachment)	mm	4430	4430	4430
A Overall length (with attachment)	mm	8460	8520	8490
B Overall height (to top of boom)	mm	2960	3130	3000
C Cab height	mm	3050	3050	3050
D Overall height (to top of handrail)	mm	3260	3260	3260
E Upper structure overall width	mm	2530	2530	2530
F Swing (rear end) radius	mm	2470	2470	2470
G Clearance height under upper structure	mm	1020	1020	1020
H Minimum ground clearance	mm	420	420	420
I Wheel base (Center to center of wheels)	mm	3190	3190	3190
L Crawler overall length	mm	3990	3990	3990
M Crawler tracks height	mm	920	920	920
J Track gauge	mm	1990	1990	1990
K Undercarriage overall width (with 600 mm shoes)	mm	2590	2590	2590

PERFORMANCE DATA

		Arm 2.6 m	Arm 3.0 m	Arm 2.2 m
Boom length	mm	5150	5150	5150
Bucket radius	mm	1350	1350	1350
Bucket wrist action	°	178	178	178
A Maximum reach at GRP	mm	8870	9220	8490
B Maximum reach	mm	9040	9380	8670
C Max. digging depth	mm	6060	6490	5660
D Max. digging height	mm	9240	9290	9010
E Max. dumping height	mm	6610	6690	6380
F Min. swing radius	mm	2990	3050	2980

DIGGING FORCE (ISO 6015)

		Arm 2.6 m	Arm 3.0 m	Arm 2.2 m
Arm digging force	kN	79	72	90
with Auto power boost	kN	84	77	95
Bucket digging force	kN	112	112	112
with Auto power boost	kN	118	118	118

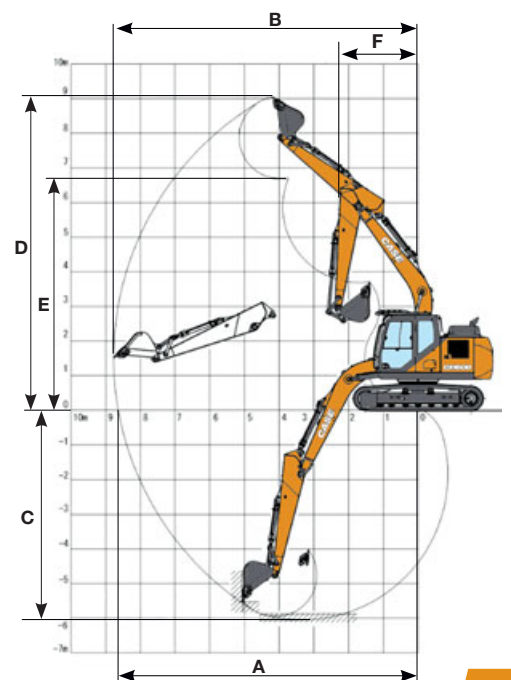

LIFTING CAPACITY

CX160D

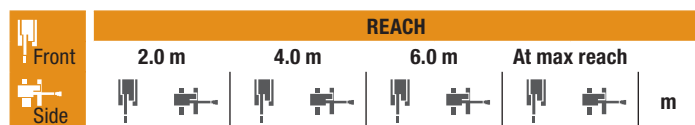

2.6 m length, 600 mm shoes. Max reach 7.69 m

	2.0 m	4.0 m	6.0 m	At max reach					
6.0 m			3920*	3340	2660*	2660*	6.37		
4.0 m		6090*	6000	5000	3240	2540*	2330	7.34	
2.0 m		8890*	5340	4760	3030	2650*	2100	7.69	
0 m		8560	4970	4580	2680	3010*	2120	7.49	
-2.0 m	8100*	8100*	8500	4910	4530	2820	3890	2450	6.7
-4.0 m	13650*	13650*	8050*	5100			5960*	3720	5.5

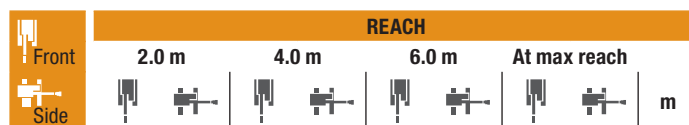

2.2 m length, 600 mm shoes. Max reach 7.32 m

	2.0 m	4.0 m	6.0 m	At max reach					
6.0 m						3510*	3360	5.92	
4.0 m		6720*	5910	4970	3220	3340*	2540	6.96	
2.0 m		8940	5280	4760	3030	3510*	2270	7.32	
0 m		8580	4990	4600	2890	3620	2310	7.11	
-2.0 m	8950*	8950*	8580	4990	4590	2880	4330	2730	6.28
-4.0 m		7160*	5230				6120*	4510	4.46

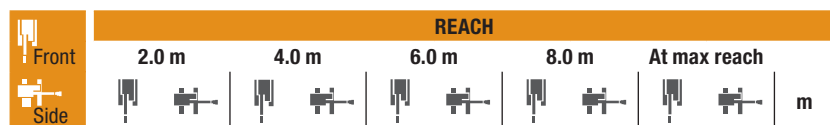

3.0 m length, 600 mm shoes. Max reach 8.03 m

	2.0 m	4.0 m	6.0 m	8.0 m	At max reach					
8.0 m						2820*	2820*	4.94		
6.0 m			3850*	3390		2390*	2390*	6.78		
4.0 m			4690*	3260		2310*	2160	7.7		
2.0 m		8240*	5410	4770	3030	2570*	1950	2440*	1940	8.3
0 m		8550	4940	4550	2830		2790*	1950	7.84	
-2.0 m	7650*	7650*	8410	4830	4470	2750		3540	2220	7.9
-4.0 m	14120*	14120*	8570	4960				5120	3170	5.56

GENERAL PURPOSE BUCKET (DIRECT MOUNT)

CAPACITY (ISO7451 HEAPED)	WIDTH	WEIGHT	ARM 2.6 m	ARM 3.0 m	ARM 2.2 m
0.24 m ³	470 mm	350 kg	○	○	○
0.36 m ³	600 mm	389 kg	○	○	○
0.50 m ³	750 mm	437 kg	○	○	○
0.62 m ³	900 mm	475 kg	○	●	○
0.70 m ³	1000 mm	501 kg	●	●	○
0.78 m ³	1100 mm	536 kg	●	■	●
0.87 m ³	1200 mm	562 kg	■	■	●
1.00 m ³	1350 mm	625 kg	■	×	■

GENERAL PURPOSE SCOOP BUCKET (WITH CASE MULTI-FIT S COUPLER)

CAPACITY (ISO7451 HEAPED)	WIDTH	WEIGHT	ARM 2.6 m	ARM 3.0 m	ARM 2.2 m
0.24 m ³	470 mm	338 kg	○	○	○
0.36 m ³	600 mm	377 kg	○	○	○
0.50 m ³	750 mm	417 kg	○	●	○
0.62 m ³	900 mm	466 kg	●	■	○
0.70 m ³	1000 mm	492 kg	■	■	●
0.78 m ³	1100 mm	528 kg	■	×	■
0.87 m ³	1200 mm	554 kg	×	×	■

TILTABLE DITCH CLEANING BUCKET

CAPACITY (ISO7451 HEAPED)	WIDTH	WEIGHT	ARM 2.6 m	ARM 3.0 m	ARM 2.2 m
0.46 m ³	1500 mm	644 kg	○	○	○
0.55 m ³	1800 mm	700 kg	●	●	○
0.61 m ³	2000 mm	739 kg	●	■	●
0.68 m ³	2200 mm	804 kg	■	■	●
0.74 m ³	2400 mm	836 kg	■	×	■

○ Rated material density up to 2 ton/m³ ● Rated material density up to 1.6 ton/m³ ■ Rated material density up to 1.2 ton/m³ × Not applicable

* The above loads (kg) are compliant to the ISO standards and refer to the excavator equipped without bucket. The indicated loads are no more than 87% of hydraulic system lift capacity or 75% of static tipping load. Values marked with an asterisk (*) are limited by the hydraulic lifting capacity.

CX D-SERIES

CX180D

ENGINE

Model	ISUZU AR-4JJ1X
Type	Water-cooled, 4-cycle diesel, 4-cylinder in line, High pressure common rail system (electric control), turbocharger with air cooled intercooler, SCR system
Emissions	Tier 4 Final / Eu stage IV
Number of cylinders/Displacement (l)	4 / 2.99
Bore and stroke (mm)	95.4 x 104.9
Rated flywheel horse power	
SAE J1349, ISO 9249	83.2 kW / 111 hp at 2200 min ⁻¹
ISO 14396	86 kW / 115 hp at 2200 min ⁻¹
Maximum torque	
SAE J1349, ISO 9249	349 Nm at 1800 min ⁻¹
ISO 14396	356 Nm at 1800 min ⁻¹

HYDRAULIC SYSTEM

Main pumps	2 variable displacement axial piston pumps with regulating system
Max. oil flow (l/min)	2 x 142 at 2200 min ⁻¹
Working circuit pressure	
Boom/Arm/Bucket (MPa)	34.3
	36.3 with auto power up
Swing circuit (MPa)	27.9
Travel circuit (MPa)	34.3
Pilot pump	
	1 gear pump
Max. oil flow (l/min)	22
Working circuit pressure (MPa)	3.9
Boom Cylinders	
Bore (mm)	115
Stroke (mm)	1179
Arm Cylinders	
Bore (mm)	125
Stroke (mm)	1280
Bucket Cylinders	
Bore (mm)	105
Stroke (mm)	985

SWING

Swing Motor	Fixed displacement axial piston motor
Maximum swing speed (min ⁻¹)	11.5
Swing torque (Nm)	45100

FILTERS

Suction filter (µm)	105
Return filter (µm)	6
Pilot line filter (µm)	8

ELECTRICAL SYSTEM

Voltage (V)	24
Alternator (Amp)	50
Starter (V/kW)	24/4.0
Battery	2 x 12 V - 72 Ah/5HR

UNDERCARRIAGE

Travel motor	Variable displacement axial piston motor
Travel speeds	
High (km/h - automatic travel speed shifting)	4.0
Low (km/h)	2.3
Drawbar pull (kN)	190
Number of carrier rollers (each side)	2
Number of track rollers (each side)	7
Number of shoes (each side)	46

CIRCUIT AND COMPONENT CAPACITIES

Fuel tank (l)	300
Hydraulic system (l)	167
Hydraulic tank (l)	82
Adblue tank (l)	85

SOUND LEVEL

External guaranteed sound level	
(EU Directive 2000/14/EC)	LwA 100 dB(A)
Operator cab sound pressure level (ISO 6396)	LpA 69 dB(A)

WEIGHT AND GROUND PRESSURE

(with 2.62 m Arm, 0.62 m³ bucket, 600 mm grouser shoes, operator, lubricant, coolant, full fuel tank and FOPS protection level 2)

CX180D

Weight	18500 kg
Ground Pressure	0.041 MPa
Counterweight	3170 kg

SPECIFICATIONS

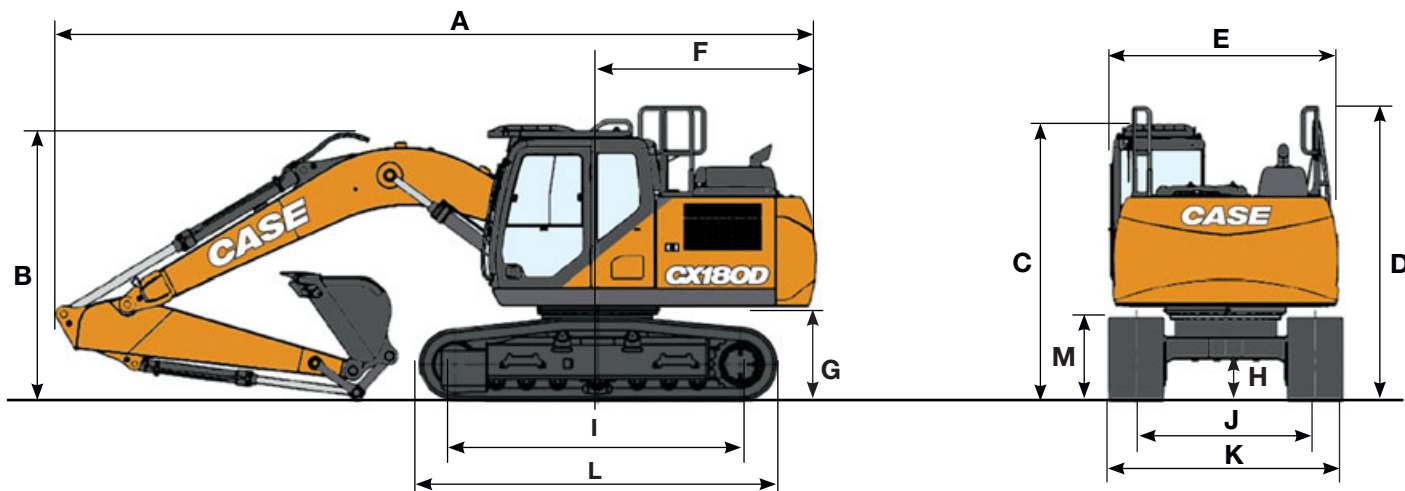

GENERAL DIMENSIONS

		Arm 2.6 m	Arm 3.0 m	Arm 2.2 m
Overall length (without attachment)	mm	4520	4520	4520
A Overall length (with attachment)	mm	8460	8510	8490
B Overall height (to top of boom)	mm	2960	3120	3000
C Cab height	mm	3070	3070	3070
D Overall height (to top of handrail)	mm	3280	3280	3280
E Upper structure overall width	mm	2530	2530	2530
F Swing (rear end) radius	mm	2470	2470	2470
G Clearance height under upper structure	mm	1040	1040	1040
H Minimum ground clearance	mm	440	440	440
I Wheel base (Center to center of wheels)	mm	3370	3370	3370
L Crawler overall length	mm	4180	4180	4180
M Crawler tracks height	mm	925	925	925
J Track gauge	mm	2200	2200	2200
K Undercarriage overall width (with 600 mm shoes)	mm	2800	2800	2800

PERFORMANCE DATA

		Arm 2.6 m	Arm 3.0 m	Arm 2.2 m
Boom length	mm	5150	5150	5150
Bucket radius	mm	1350	1350	1350
Bucket wrist action	°	178	178	178
A Maximum reach at GRP	mm	8870	9210	8490
B Maximum reach	mm	9040	9380	8670
C Max. digging depth	mm	6040	6470	5650
D Max. digging height	mm	9250	9300	9030
E Max. dumping height	mm	6630	6710	6400
F Min. swing radius	mm	2990	3050	2980

DIGGING FORCE (ISO 6015)

		Arm 2.6 m	Arm 3.0 m	Arm 2.3 m
Arm digging force	kN	79	72	90
with Auto power boost	kN	84	77	95
Bucket digging force	kN	112	112	112
with Auto power boost	kN	118	118	118

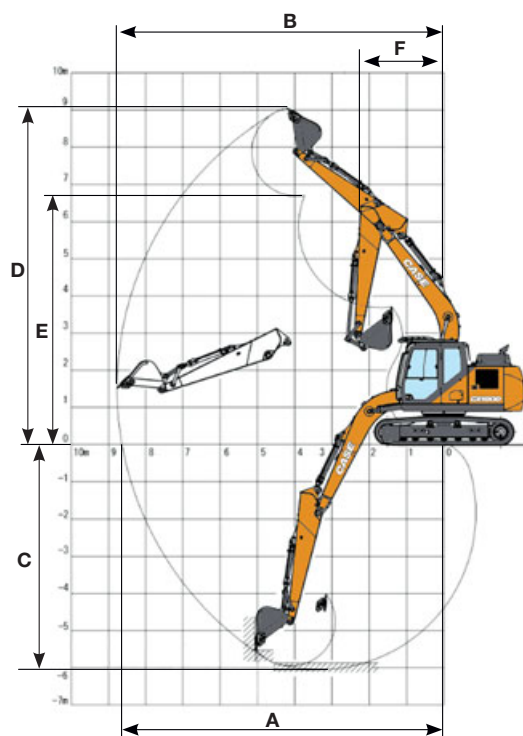

LIFTING CAPACITY

CX180D



2.6 m length, 600 mm shoes. Max reach 7.69 m

	2.0 m		4.0 m		6.0 m		At max reach		
6.0 m					3940*	3940*	2660*	2660*	6.38
4.0 m			6100*	6100*	5080*	3860	2540*	2540*	7.35
2.0 m			8910*	6480	5520	3640	2650*	2540	7.69
0 m			10110	6100	5320	3470	3020*	2580	7.48
-2.0 m	8140*	8140*	10050	6040	5280	3430	3940*	2990	6.69
-4.0 m	13600*	13600*	8020*	6240			5960*	4530	5.3



2.2 m length, 600 mm shoes. Max reach 7.32 m

	2.0 m		4.0 m		6.0 m		At max reach				
6.0 m									3510*	3510*	5.94
4.0 m			6740*	6740*	5430*	3840	3340*	3040	6.96		
2.0 m			9450*	6420	5510	3650	3500*	2750	7.32		
0 m			10130	6120	5350	3500	4040*	2800	7.11		
-2.0 m	9010*	9010*	10050*	6120	5340	3490	5040	3320	6.27		
-4.0 m			7110*	6380			6110*	5500	4.44		

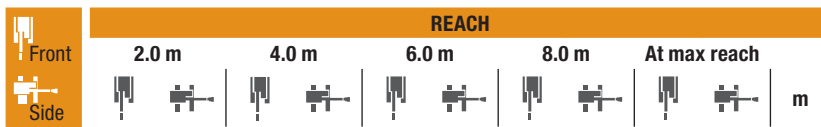

3.0 m length, 600 mm shoes. Max reach 8.03 m

	2.0 m		4.0 m		6.0 m		8.0 m		At max reach		
8.0 m									2820*	2820*	4.96
6.0 m					3860*	3860*			2380*	2380*	6.79
4.0 m					4690*	3880			2310*	2310*	7.7
2.0 m			8260*	6560	5520	3650	2580*	2380	2440*	2360	8.3
0 m			10100	6080	5300	3450			2790*	2380	7.83
-2.0 m	7690*	7690*	9960	5960	5210	3370			3620*	2720	7.8
-4.0 m	14190*	14190*	8710*	6100					5890*	3870	5.54

GENERAL PURPOSE BUCKET (DIRECT MOUNT)

CAPACITY (ISO7451 HEAPED)	WIDTH	WEIGHT	ARM 2.6 m	ARM 3.0 m	ARM 2.2 m
0.24 m ³	470 mm	350 kg	○	○	○
0.36 m ³	600 mm	389 kg	○	○	○
0.50 m ³	750 mm	437 kg	○	○	○
0.62 m ³	900 mm	475 kg	○	○	○
0.70 m ³	1000 mm	501 kg	○	○	○
0.78 m ³	1100 mm	536 kg	●	●	○
0.87 m ³	1200 mm	562 kg	●	■	○
1.00 m ³ *	1350 mm	625 kg	■	■	●

* remove for road transport with 3.05 m arm

GENERAL PURPOSE SCOOP BUCKET (WITH CASE MULTI-FIT S COUPLER)

CAPACITY (ISO7451 HEAPED)	WIDTH	WEIGHT	ARM 2.6 m	ARM 3.0 m	ARM 2.2 m
0.24 m ³	470 mm	338 kg	○	○	○
0.36 m ³	600 mm	377 kg	○	○	○
0.50 m ³	750 mm	417 kg	○	○	○
0.62 m ³	900 mm	466 kg	○	●	○
0.70 m ³	1000 mm	492 kg	●	●	○
0.78 m ³	1100 mm	528 kg	■	■	○
0.87 m ³	1200 mm	554 kg	■	■	●
1.00 m ³	1350 mm	614 kg	×	×	■

TILTABLE DITCH CLEANING BUCKET

CAPACITY (ISO7451 HEAPED)	WIDTH	WEIGHT	ARM 2.6 m	ARM 3.0 m	ARM 2.2 m
0.46 m ³	1500 mm	644 kg	○	○	○
0.55 m ³	1800 mm	700 kg	○	○	○
0.61 m ³	2000 mm	739 kg	●	●	○
0.68 m ³	2200 mm	804 kg	●	■	○
0.74 m ³	2400 mm	836 kg	■	■	●

○ Rated material density up to 2 ton/m³ ● Rated material density up to 1.6 ton/m³ ■ Rated material density up to 1.2 ton/m³ × Not applicable

* The above loads (kg) are compliant to the ISO standards and refer to the excavator equipped without bucket. The indicated loads are no more than 87% of hydraulic system lift capacity or 75% of static tipping load. Values marked with an asterisk (*) are limited by the hydraulic lifting capacity.

www.casece.com

EXPERTS FOR THE REAL WORLD
SINCE 1842

CASE
CONSTRUCTION



Form No. 20132GB - MediaCross Firenze - 02/17

**CNH INDUSTRIAL
DEUTSCHLAND GMBH**
Case Baumaschinen
Benzstr. 1-3 - D-74076 Heilbronn
DEUTSCHLAND

CNH INDUSTRIAL FRANCE, S.A.
16-18 Rue des Rochettes
91150 Morigny-Champigny
FRANCE

CNH INDUSTRIAL - UK
First Floor, Barclay Court 2,
Heavens Walk,
Doncaster - DN4 5HZ
UNITED KINGDOM

CNH INDUSTRIAL - SOUTH AFRICA
Waterfall Business Park
Bekker Street, Howick Close
1685 Midrand - Johannesburg
REPUBLIC OF SOUTH AFRICA

**CNH INDUSTRIAL
MAQUINARIA SPAIN, S.A.**
Avda. José Gárate, 11
28823 Coslada (Madrid)
ESPAÑA

CNH INDUSTRIAL ITALIA SPA
Strada di Settimo, 323
10099 San Mauro Torinese (TO)
ITALIA

**CASE CUSTOMER CENTRE
PARIS**
RN 330 - Penchard
77122 - Monthyon
FRANCE

CNH INDUSTRIAL - MIDDLE EAST
DAFZA - Dubai Airport Free Zone
West Wing 4 B, Office 642
P.O. Box 54588, Dubai,
UNITED ARAB EMIRATES

NOTE: Standard and optional fittings can vary according to the demands and specific regulations of each country. The illustrations may include optional rather than standard fittings - consult your Case dealer. Furthermore, CNH Industrial reserves the right to modify machine specifications without incurring any obligation relating to such changes.

Conforms to directive 2006/42/EC

CASE
00800-2273-7373

The call is free from a land line.
Check in advance with your Mobile Operator if you will be charged. Toll free number not available from all calling areas.

