

**WHEELED EXCAVATORS  
WX148 | WX168**

**CASE**  
CONSTRUCTION



**MISSION  
ACCOMPLISHED**

[www.casece.com](http://www.casece.com)

**EXPERTS FOR THE REAL WORLD  
SINCE 1842**

# WHEELED EXCAVATORS





# THE “8 SERIES”

## POWER AND CONTROL

The WX wheeled excavators are designed to deliver a maximum of productivity and precision.

The extra powerful hydraulics are managed by the Case Intelligent Hydraulic System (CIHS) control, which offers a single CPU for improved controllability and simplified diagnostics. The Case wheeled excavators use a 3-pump hydraulic system, with one pump dedicated to the slew function. This provides continuous movement and allows the operator to multi-function the controls for smooth, productive digging performance.

Case wheel excavators are equipped with Case Intelligent Swing system (CIS) allowing the operator to adjust the upperstructure slew speed to suit to all working site conditions.

Two new working modes, easily switchable on the joystick, have been implemented to better adapt the machine behaviour to specific tasks: STANDARD MODE suited for general applications and precision grading with maximum fuel savings; POWER MODE for a maximised production and faster cycles. The Automatic Powerboost function delivers maximum performance for heavy breakout and lifting operations. The Power Limit Control feature monitors the engine and hydraulic pumps to optimise power output.

## SUPERIOR VERSATILITY

The flow and pressure to the attachments is easy to adjust and up to 12 settings for different attachments can be memorised.







CASE

WX148





## POWERTRAIN

Our WX excavators drive through a fully automatic hydrostatic powershift transmission and heavy duty ZF axles, providing fast travel speed between working sites and excellent traction. An improved orbitrol steering system delivers effortless and precise control. A larger steering angle makes it even easier to move in confined areas. With a creep speed function and high ground clearance, the machines are also capable of tackling the toughest of site conditions.

Excellent drawbar pull is a feature of all three machines and the axles have an auto-locking feature for maximum stability when working without stabilisers. Multi-disc wet brakes and axle oil change intervals of 2,000 hours will reduce your customers' ownership and operating costs.

## TOTAL STABILITY

The new WX design leads to an outstanding stability even on tires only.

Our wheeled excavators have always boasted a robust design and sturdy build quality. These new WX models are no exception, with a strong chassis providing the option of a dozer blade, the dozer blade and stabilisers, or stabilisers front and rear for total balance and a stable working platform. The dozer blade with parallel kinematics is made extra-robust in curved design for best material retention.





# WHEELED EXCAVATORS





## FIRST-CLASS COMFORT

The inclination of the steering column is continuously adjustable to fit the operator's best working position; the controls are individually adjustable to match their preferences; the adjustable air suspended and heated seat combined with the ergonomic design of armrests and foot pedals provide the best possible workstation.

The tinted safety glass, sun blinds and transparent rain protection above the front window provide comfortable working conditions, while the automatic air conditioning maintains a comfortable in-cab climate for more productive work.

A hot and cool box, plenty of storage compartments, a radio with USB support, a microphone for handsfree conversation, a front aux. port and a 12V auxiliary socket complete the operator's comfortable workstation.

## EASY TO OPERATE

The controls layout is designed to minimise fatigue, with all travel functions and switches easily accessible and grouped on the steering column. The machine's information is easy to access and understand on the in-cab monitor, so the operator can focus on the job. A new engine speed and working mode selection dial makes it easy for the operator to set the machine up in any working situation. The dial delivers low idle speed, two lifting modes, and three Eco working modes. It also provides access to the Heavy Mode for maximum digging performance. The new levelling mode can be easily activated in Eco or Heavy mode by simply pressing a switch on the right hand joystick. The blade and each of the stabilizers are proportionally operated. Each of the stabilizers can be easily activated by switches.

## ALL-ROUND VISIBILITY

Large glazed surfaces, safety tinted glass, one-piece right-hand side window and large roof window provide superior visibility all around.

Standard working lights on the boom and cab front add to the excellent visibility.

The standard rear view camera further enhances visibility to the rear.



# WHEELED EXCAVATORS



## SAFETY

### SAFE ATTACHMENT OPERATION

Boom cylinders feature safety valves as standard. For added safety, a complete object handling kit (safety valves on dipper, loading hook, overload warning) and a heavy-duty holder for grabs are available as options.

### ROPS/FOPS CAB

The reinforced structure of the cab is ROPS and FOPS certified.







## EASY MAINTENANCE

Big and wide-opening hoods provide easy access to all service points. Maintenance operations are quick and easy with the grouped, easily accessible greasing points, and easy to reach filters at the rear of the machine. The extended greasing intervals for the attachment (up to 500 hours) maximise uptime and lower operating costs.















## THE SCIENCE BIT

The Case SiteWatch telematics system uses a high-tech control unit mounted on each machine to collate information from that machine and from GPS satellites. This data is then sent wirelessly through the mobile communication networks to the Case Telematics Web Portal.



## SiteWatch: centralised fleet control benefits at your fingertips

### Measure your true asset availability and optimise it

- Eliminate the “phantom fleet”: SiteWatch allows to identify spare units or under loaded machines on each site.
- Become able to reallocate units where they are more needed.
- Forward Maintenance Planning is easier since the actualised working hours are always available.
- Extend the benefits of SiteWatch to the rest of your fleet: SiteWatch can be installed on the units of other brands as well.

### Challenge your Total Cost of Ownership!

- Being able to compare the fuel usage of different machine types will allow you choose the right equipment.
- Save on transport costs with planned and grouped maintenance tasks.
- Peace of mind, optimised uptime and lower repair costs: with preventive maintenance you can for example be alerted if the engine needs to be serviced and avoid a disruptive breakdown.
- Be able to compare your asset Return On Investment on different sites.
- Your equipment is used only during working hours. You can set up alerts so that you know if it is in use during the weekend or at night.
- Integrate with the programmed maintenance package, so that you can be sure every machine is at the right place at the right time.

### More Safety, Lower Insurance Premium

- Keep thieves away: dissuade them from attacking your asset because it is geo-localised. SiteWatch is hidden so that thieves can't find it quickly.
- Your fleet is used only where you decide. You can define a virtual fence and receive an email when a machine exits that perimeter.

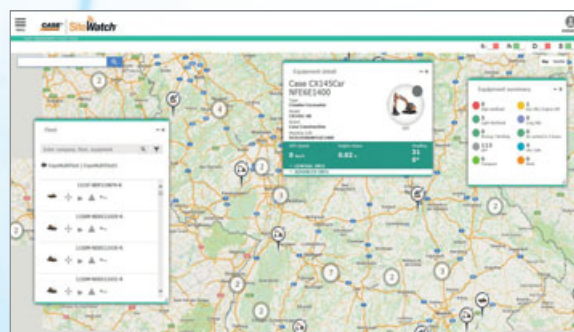



## STANDARD EQUIPMENT

Latest generation FPT Stage III / Tier 3 diesel engine  
Direct injection with turbo charger and charge air cooling  
Air filter with safety cartridge  
Engine filters (oil, fuel and water separator) in remote position  
Auto-idling system  
Cold starting equipment (-25°C)  
Pump management system by power limit control  
Electrohydraulic servo control  
3-pumps hydraulic system with two service pumps and separate swing pump  
Auto Power Boost system  
8 selectable power stages with permanent Power Boost in lift stages  
Automatic power increase in road travel mode  
Automatic battery main switch (coupled to ignition key)  
Electronic immobiliser (PIN code)  
12 V electrical auxiliary supply in cab  
Swing hydrostatic braking  
Automatic / permanent swing brake modes  
Swing drive with low-wearing disc brake  
CIS (CASE intelligent system) : Adjustable swing acceleration (power) and deceleration (brake)  
Cab according ROPS ISO 12117-2: 2008  
FOPS Level 2  
Noise-insulated and viscous mounted cab  
Tinted safety glazing all around, full up and over windscreen  
Sun blinds, large roof window, transparent rain protection  
Automatic air conditioning

## OPTIONS

Hydraulic circuit for hammer / shears  
Hydraulic circuit for grab rotation 22 l/min - ON/OFF control  
Hydraulic circuit for grab rotation 80 l/min - PROPORTIONAL Control  
Quick coupler provision on upperframe  
Biodegradable hydraulic oil (Panolin)  
Front Guard Protective system FGPS  
20 km/h speed  
35 km/h speed  
Single or twin tyres

Rear View Camera with dedicated screen  
Radio with Bluetooth  
Control panel with LCD monitor integrating error diagnosis function and analogical gauges for engine cooling temperature and fuel level  
Ergonomic design of arm rests and foot pedals  
Air suspension seat individually adjustable for height and incline  
Consoles adjustable for height and length  
Forward/Reverse shifting on right joystick  
Centralised and independent control of blade and stabilizers on right joystick  
2 front headlights (cab mounted)  
Road travel lights (front and rear)  
Robust, shielded arc-welded, modular chassis in box section design  
Power Shift gear box with manual / automatic gear shifting  
Heavy duty axles with brakes for play-free work  
Hydrostatic travel braking  
Creeper speed  
Large toolbox under the step (right side)  
Encased ball bearing slew ring with long-life lubrication  
Manual / automatic axle locking system  
Electric diesel filling system  
Safety valves on boom cylinders  
Cylinders with end-stroke damping system  
Long interval greasing bushings (500 hours)  
Centralized greasing nipples on upperframe and boom  
2 working lights on boom

Dozer blade with parallel guidance  
Heavy duty stabilizers with cylinder protection guards  
Transport holder for clamshell grab  
Blade cylinders protection guard  
One piece boom, triple articulation (2 piece boom)  
Arms: WX148: 2.10 - 2.45 - 2.95 m  
          WX168: 2.20 - 2.60 - 3.10 m  
Object handling kit with safety valve on arm cylinder, overloading warning device and load hook or load eye.

Standard and optional equipment shown can vary by country.



# WHEELED EXCAVATORS

## WX148

### SPECIFICATIONS

#### ENGINE

Net engine power (ISO 14396/ECE R120) \_\_\_\_\_ 90 kW / 121 hp  
 Rated \_\_\_\_\_ 2000 rpm  
 Make and model \_\_\_\_\_ F4GE9484D J601  
 Type \_\_\_\_\_ Water-cooled, direct injection type diesel engine with intercooler turbo-charger  
 Displacement \_\_\_\_\_ 4.5 l  
 Number of cylinders \_\_\_\_\_ 4  
 Bore x stroke \_\_\_\_\_ 104 x 132 mm  
 Maximum torque at 1200 rpm \_\_\_\_\_ 525 Nm

#### ELECTRICAL SYSTEM

Voltage \_\_\_\_\_ 24 V  
 Batteries \_\_\_\_\_ 2 x 12 V  
 Battery rating (each) \_\_\_\_\_ 100 Ah  
 Alternator \_\_\_\_\_ 70 A  
 Starter motor \_\_\_\_\_ 4 kW

#### TRANSMISSION

	km/h	km/h
Max Road travel speed	20	35
Max Field travel speed	5	8
Creep speed	2.5	2.5
Maximum drawbar pull (field) _____		92 kN

Power Shift multi-disc gearbox shiftable under load.  
 Automatic or manual gear shift control.  
 Travel mode automatically engaged by pressing accelerator pedal.

#### HYDRAULIC SYSTEM

2 x Primary pumps \_\_\_\_\_ 3 variable displacement, axial piston  
 Total maximum flow \_\_\_\_\_ 352 l/min (2 x 140 + 72)  
 Auxiliary low flow, optional (on/off) \_\_\_\_\_ 22 l/min  
 Auxiliary medium flow, optional (proportional) \_\_\_\_\_ 80 l/min  
 Implement /travel pressure \_\_\_\_\_ 340/370 bar  
 Power Boost \_\_\_\_\_ 370 bar  
 Swing circuit pressure \_\_\_\_\_ 360/390 bar  
 Pilot pump \_\_\_\_\_ 45 bar  
 Boom cylinder mono \_\_\_\_\_ 100 x 1028 mm  
 Boom cylinder 2-piece boom \_\_\_\_\_ 100 x 972 mm  
 Arm cylinder \_\_\_\_\_ 115 x 1120 mm

Bucket cylinder \_\_\_\_\_ 95 x 903 mm  
 Positioning cylinder \_\_\_\_\_ 135 x 645 mm  
 Cylinder end stroke damping.  
 Electrohydraulic servo-control.  
 Three-pump hydraulics with two main pumps and separate swing pump. 8 selectable power stages with permanent Power Boost in lift stages: Low idle, Lift 1, Lift 2, Eco 1, Eco 2, Eco 3, Heavy, Roadtravel  
 Adjustable swing acceleration (power) and deceleration (brake)  
 Automatic power increase in the drive mode.

#### SWING DRIVE

Swing speed \_\_\_\_\_ 9 rpm  
 Swing torque (SAE J1371) \_\_\_\_\_ 36 kNm  
 The swing function is operated by a hydraulic closed circuit coupled with a mechanical reducer integrating an automatic static brake.  
 The hydro-static swing brake is adjustable in 3 settings.

#### BRAKES

Service brakes: play free, oil bath multi disc type integrated in all four wheel hubs.  
 Work brake: acts on service brakes and locks front axle oscillation.  
 Parking brake: spring type mechanical acting on the transmission.  
 Emergency brake: double braking circuit and automatic parking and brake actuation with the engine shut down.

#### STEERING

Type \_\_\_\_\_ ORBITROL with safety valve  
 Pump \_\_\_\_\_ gear type  
 Steering cylinder \_\_\_\_\_ double effect, integrated in axle

#### TYRES

Twin tyres \_\_\_\_\_ 10.00-20/80-22.5  
 Single tyres \_\_\_\_\_ 18R 19.5, 600/40-22.5  
 Tyre availability can be limited by local homologation.

#### CAPACITIES

Engine oil \_\_\_\_\_ 12,5 l  
 Cooling system \_\_\_\_\_ 22 l  
 Fuel tank \_\_\_\_\_ 190 l  
 Hydraulic system (incl. tank) \_\_\_\_\_ 200 l for mono  
 \_\_\_\_\_ 210 l for triple articulation



# GENERAL DIMENSIONS

## WX148

equipped with twin tires 10.00 - 20

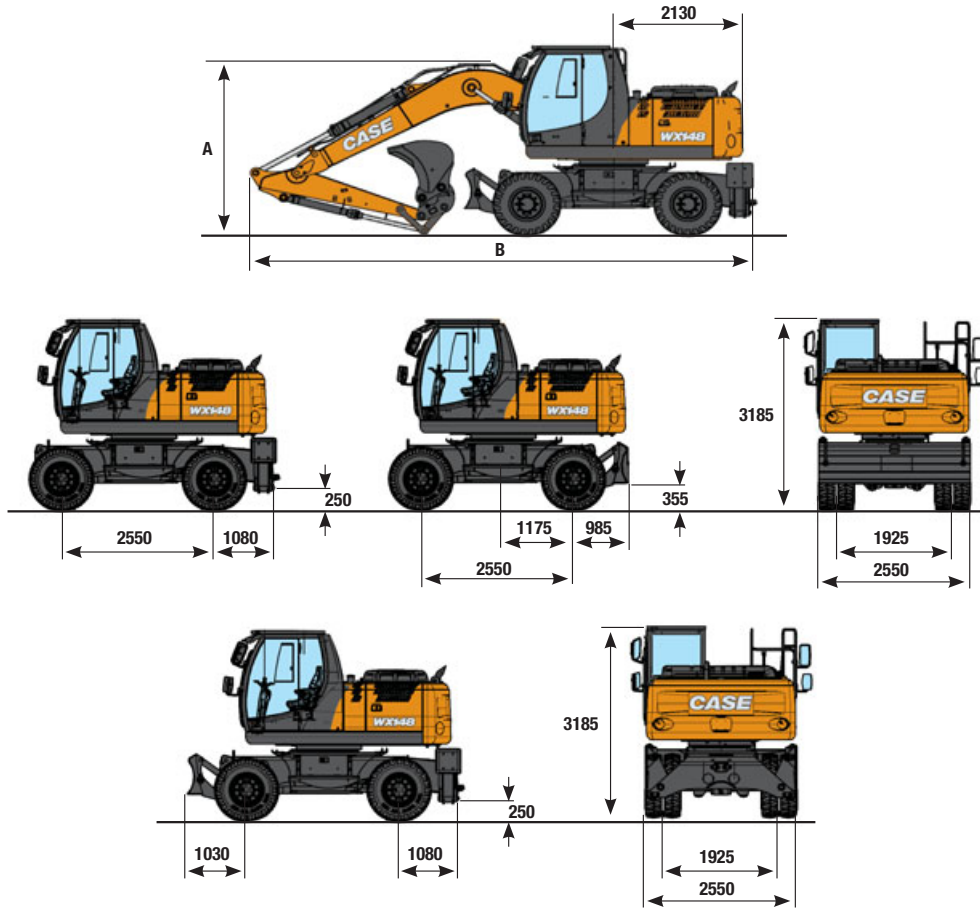

### TRIPLE ARTICULATION 5.15 m

### MONOBOOM 4.75 m

	Arm 2.10 m	Arm 2.45 m	Arm 2.95 m	Arm 2.10 m	Arm 2.45 m	Arm 2.95 m
<b>A</b>	2620 mm	2710 mm	3050 mm	2890 mm	3115 mm	3605 mm
<b>B</b> with rear blade	8075 mm	8085 mm	8055 mm	7850 mm	7880 mm	7895 mm
<b>B</b> with rear stabilizers	8240 mm	8250 mm	8220 mm	8015 mm	8045 mm	8065 mm

## OPERATING WEIGHT WX148

2.55 axle width include bucket 480 kg and quick coupler 250 kg (with 10.00-20)

### TRIPLE ARTICULATION

### MONOBOOM

	Arm 2.10 m	Arm 2.45 m	Arm 2.95 m	Arm 2.10 m	Arm 2.45 m	Arm 2.95 m
Rear blade	15450 kg	15550 kg	15600 kg	15100 kg	15200 kg	15250 kg
Stabilizers	15750 kg	15800 kg	15850 kg	15400 kg	15500 kg	15550 kg
Blade and stabilizers	16300 kg	16350 kg	16400 kg	16000 kg	16050 kg	16100 kg



# PERFORMANCE DATA

## WX148

### TRIPLE ARTICULATION

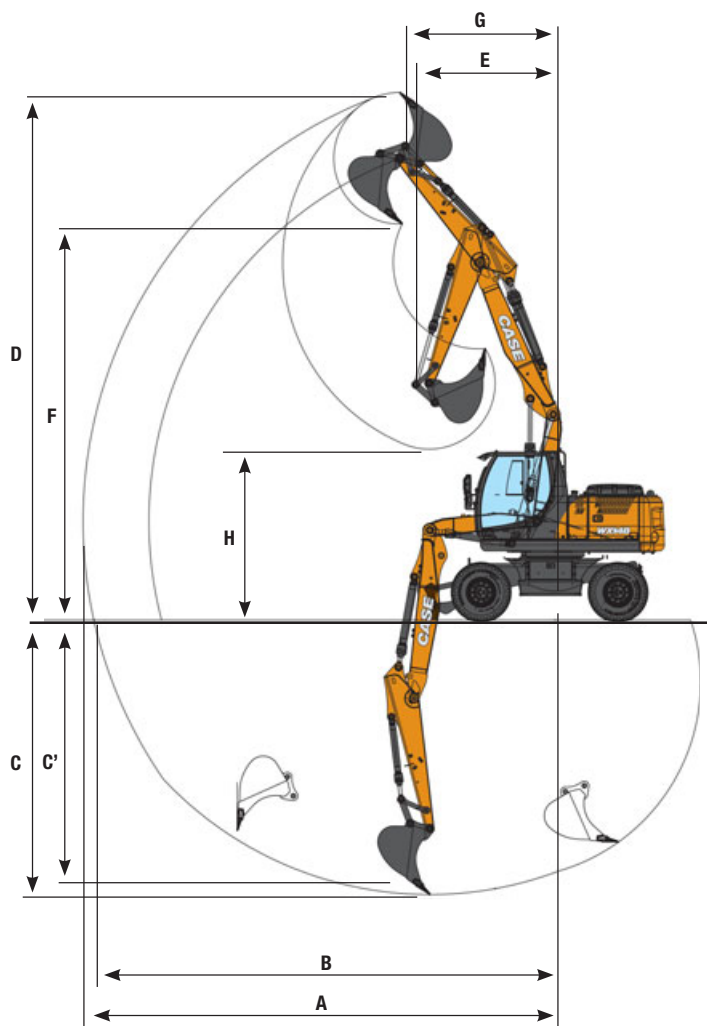

### MONOBOOM

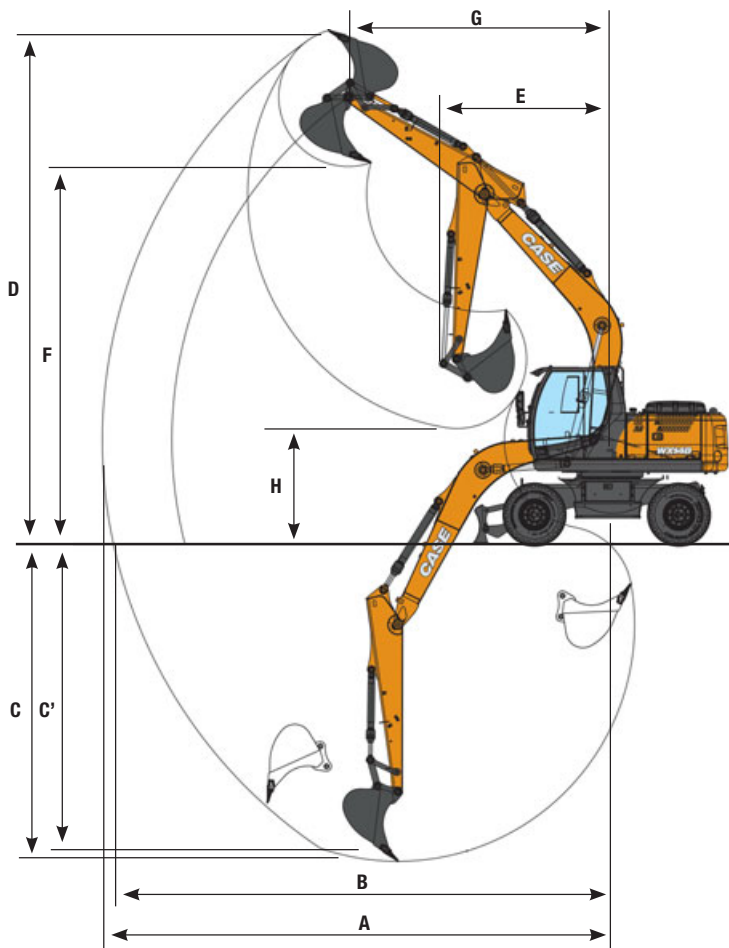

	TRIPLE ARTICULATION			MONOBOOM		
	Arm 2.10 m	Arm 2.45 m	Arm 2.95 m	Arm 2.10 m	Arm 2.45 m	Arm 2.95 m
<b>A</b> Max. digging reach	8400 mm	8800 mm	9300 mm	8200 mm	8500 mm	9000 mm
<b>B</b> Max. digging reach at ground level	8300 mm	8600 mm	9100 mm	8000 mm	8300 mm	8800 mm
<b>C</b> Max. digging depth	4900 mm	5200 mm	5700 mm	4900 mm	5300 mm	5800 mm
<b>C'</b> Max. depth of cut for 8' level bottom	4800 mm	5100 mm	5600 mm	4700 mm	5100 mm	5600 mm
<b>D</b> Max. digging height	9600 mm	9900 mm	10300 mm	8600 mm	8800 mm	9200 mm
<b>E</b> Min. front swing radius	2450 mm	2600 mm	3000 mm	2750 mm	2800 mm	3050 mm
<b>F</b> Max. loading height	7100 mm	7400 mm	7900 mm	6200 mm	6400 mm	6800 mm
<b>G</b> Front swing radius at max height	2390 mm	2580 mm	2810 mm	3755 mm	4025 mm	4390 mm
<b>H</b> Max. loading height (arm retracted)	3500 mm	3200 mm	2900 mm	2900 mm	2600 mm	2100 mm

## DIGGING FORCE - ISO WX148

	Arm 2.10 m	Arm 2.45 m	Arm 2.95 m
Arm digging force	74.3 kN	66.9 kN	59.5 kN
- with auto power boost	80.9 kN	72.9 kN	64.8 kN
Bucket digging force	91.3 kN	91.3 kN	91.3 kN
- with auto power boost	99.5 kN	99.5 kN	99.5 kN



# LIFTING CAPACITY

## WX148

### MONO BOOM - DIPPERSTICK 2.10 m

#### REAR BLADE UP

Front Side	REACH								
	3.0 m		4.5 m		6.0 m		At max reach		m
7.5 m							3.5*	3.5*	
6.0 m			4.0*	3.8			2.9*	2.8	5.4
4.5 m			4.4*	3.7	3.6	2.4	2.7*	2.2	6.4
3.0 m			5.3*	3.5	3.5	2.3	2.8*	1.9	6.8
1.5 m			5.1	3.2	3.4	2.2	2.8	1.8	7.0
0 m	5.9*	5.4	5.0	3.1	3.3	2.1	2.9	1.8	6.7
-1.5 m	8.2*	5.5	5.0	3.1	3.3	2.1	3.3	2.1	6.1
-3.0 m	6.1*	5.6	4.3*	3.2			3.6*	2.8	4.9

#### FRONT BLADE+REAR STAB. DOWN

Front Side	REACH								
	3.0 m		4.5 m		6.0 m		At max reach		m
7.5 m							3.5*	3.5*	
6.0 m			4.0*	4.0*			2.9*	2.9*	5.4
4.5 m			4.4*	4.4*	3.9*	3.9*	2.7*	2.7*	6.4
3.0 m			5.3*	5.3*	4.2*	4.1	2.8*	2.8*	6.8
1.5 m			6.0*	6.0*	4.5*	4.0	3.0*	3.0*	7.0
0 m	5.9*	5.9*	6.2*	5.9	4.5*	3.9	3.5*	3.3	6.7
-1.5 m	8.2*	8.2*	5.8*	5.8*	4.0*	3.9	3.9*	3.8	6.1
-3.0 m	6.1*	6.1*	4.3*	4.3*			3.6*	3.6*	4.9

### MONO BOOM - DIPPERSTICK 2.45 m

#### REAR BLADE UP

Front Side	REACH								
	3.0 m		4.5 m		6.0 m		At max reach		m
7.5 m							2.8*	2.8*	
6.0 m			3.7*	3.7*			2.4*	2.4*	5.9
4.5 m			4.1*	3.7	3.6	2.4	2.3*	2.0	6.7
3.0 m	7.6*	6.3	5.0*	3.5	3.5	2.3	2.3*	1.7	7.2
1.5 m			5.2	3.2	3.4	2.2	2.4*	1.6	7.3
0 m	6.2*	5.4	5.0	3.0	3.3	2.1	2.6	1.7	7.1
-1.5 m	8.6*	5.4	4.9	3.0	3.3	2.1	3.0	1.9	6.5
-3.0 m	6.7*	5.5	4.7*	3.1			3.6*	2.4	5.4

#### FRONT BLADE+REAR STAB. DOWN

Front Side	REACH								
	3.0 m		4.5 m		6.0 m		At max reach		m
7.5 m							2.8*	2.8*	
6.0 m			3.7*	3.7*			2.4*	2.4*	5.9
4.5 m			4.1*	4.1*	3.7*	3.7*	2.3*	2.3*	6.7
3.0 m	7.6*	7.6*	5.0*	5.0*	4.0*	4.0*	2.3*	2.3*	7.2
1.5 m			5.8*	5.8*	4.3*	3.9	2.4*	2.4*	7.3
0 m	6.2*	6.2*	6.2*	5.9	4.5*	3.9	2.8*	2.8*	7.1
-1.5 m	8.6*	8.6*	5.9*	5.8	4.2*	3.8	3.5*	3.5	6.5
-3.0 m	6.7*	6.7*	4.7*	4.7*			3.6*	3.6*	5.4

### MONO BOOM - DIPPERSTICK 2.95 m

#### REAR BLADE UP

Front Side	REACH										
	3.0 m		4.5 m		6.0 m		7.5 m		At max reach		m
7.5 m									2.3*	2.3*	
6.0 m					3.0*	2.5			2.0*	2.0*	6.5
4.5 m			3.6*	3.6*	3.3*	2.4			1.9*	1.7	7.3
3.0 m	6.5*	6.5	4.5*	3.5	3.5	2.3	2.5	1.6	1.9*	1.5	7.7
1.5 m			5.2	3.2	3.4	2.2	2.4	1.5	2.1*	1.5	7.8
0 m	6.4*	5.3	4.9	3.0	3.3	2.1	2.4	1.5	2.3*	1.5	7.6
-1.5 m	9.0*	5.3	4.9	2.9	3.2	2.0			2.6	1.6	7.0
-3.0 m	7.5*	5.4	4.9	3.0	3.3	2.0			3.2	2.0	6.0

#### FRONT BLADE+REAR STAB. DOWN

Front Side	REACH										
	3.0 m		4.5 m		6.0 m		7.5 m		At max reach		m
7.5 m									2.3*	2.3*	
6.0 m					3.0*	3.0*			2.0*	2.0*	6.5
4.5 m			3.6*	3.6*	3.3*	3.3*			1.9*	1.9*	7.3
3.0 m	6.5*	6.5*	4.5*	4.5*	3.7*	3.7*	2.6*	2.6*	1.9*	1.9*	7.7
1.5 m			5.5*	5.5*	4.1*	3.9	3.2*	2.8	2.1*	2.1*	7.8
0 m	6.4*	6.4*	6.0*	5.9	4.4*	3.8	2.7*	2.7*	2.3*	2.3*	7.6
-1.5 m	9.0*	9.0*	6.0*	5.8	4.3*	3.8			2.8*	2.8*	7.0
-3.0 m	7.5*	7.5*	5.1*	5.1*	3.4*	3.4*			3.4*	3.4*	6.0

#### REAR BLADE DOWN

Front Side	REACH								
	3.0 m		4.5 m		6.0 m		At max reach		m
7.5 m							3.5*	3.5*	
6.0 m			4.0*	4.0*			2.9*	2.9*	5.4
4.5 m			4.4*	4.2	3.9*	2.7	2.7*	2.4	6.4
3.0 m			5.3*	3.9	4.2*	2.6	2.8*	2.1	6.8
1.5 m			6.0*	3.7	4.5*	2.5	3.0*	2.0	7.0
0 m	5.9*	5.9*	6.2*	3.6	4.5*	2.4	3.5*	2.1	6.7
-1.5 m	8.2*	6.5	5.8*	3.5	4.0*	2.4	3.9*	2.4	6.1
-3.0 m	6.1*	6.1*	4.3*	3.6			3.6*	3.2	4.9

#### REAR BLADE DOWN

Front Side	REACH								
	3.0 m		4.5 m		6.0 m		At max reach		m
7.5 m							2.8*	2.8*	
6.0 m			3.7*	3.7*			2.4*	2.4*	5.9
4.5 m			4.1*	4.1*	3.7*	2.7	2.3*	2.2	6.7
3.0 m	7.6*	7.3	5.0*	4.0	4.0*	2.6	2.3*	2.0	7.2
1.5 m			5.8*	3.7	4.3*	2.5	2.4*	1.9	7.3
0 m	6.2*	6.2*	6.2*	3.5	4.5*	2.4	2.8*	1.9	7.1
-1.5 m	8.6*	6.4	5.9*	3.5	4.2*	2.4	3.5*	2.2	6.5
-3.0 m	6.7*	6.5	4.7*	3.5			3.6*	2.8	5.4

#### REAR BLADE DOWN

Front Side	REACH										
	3.0 m		4.5 m		6.0 m		7.5 m		At max reach		m
7.5 m									2.3*	2.3*	
6.0 m					3.0*	2.8			2.0*	2.0*	6.5
4.5 m			3.6*	3.6*	3.3*	2.7			1.9*	1.9*	7.3
3.0 m	6.5*	6.5*	4.5*	4.0	3.7*	2.6	2.6*	1.8	1.9*	1.8	7.7
1.5 m			5.5*	3.7	4.1*	2.5	3.2*	1.8	2.1*	1.7	7.8
0 m	6.4*	6.3	6.0*	3.5	4.4*	2.4	2.7*	1.7	2.3*	1.7	7.6
-1.5 m	9.0*	6.3	6.0*	3.4	4.3*	2.3			2.8*	1.9	7.0
-3.0 m	7.5*	6.4	5.1*	3.4	3.4*	2.4			3.4*	2.3	6.0

The above loads (kg) are compliant to the ISO standards and refer to the excavator equipped with bucket. The indicated loads are no more than 87% of hydraulic system lift capacity or 75% of static tipping load. Values marked with an asterisk (\*) are limited by the hydraulic lifting capacity rather than the tipping load.



# LIFTING CAPACITY

## WX148

### TRIPLE ARTICULATION - DIPPERSTICK 2.10 M

#### REAR BLADE UP

Front Side	REACH								
	3.0 m		4.5 m		6.0 m		At max reach		m
7.5 m							4.1*	4.1*	
6.0 m			4.5*	3.8			3.3*	2.5	5.8
4.5 m	6.6*	6.6*	4.9*	3.8	3.7	2.4	3.0	2.0	6.7
3.0 m	7.6*	6.4*	5.4	3.7	3.6*	2.4	2.7	1.7	7.1
1.5 m	8.7*	6.3	5.3	3.7	3.6	2.3	2.6	1.7	7.2
0 m	9.8*	6.3	5.4*	3.6	3.4	2.2	2.7	1.7	7.0
-1.5 m	10.1*	6.1	5.3	3.3	3.4	2.1	3.0	1.9	6.4
-3.0 m	9.4*	5.9	4.8*	3.2			4.2*	3.0	4.8

#### FRONT BLADE+REAR STAB. DOWN

Front Side	REACH								
	3.0 m		4.5 m		6.0 m		At max reach		m
7.5 m							4.1*	4.1*	
6.0 m			4.5*	4.5*			3.3*	3.3*	5.8
4.5 m	6.6*	6.6*	4.9*	4.9*	4.1*	4.1*	3.1*	3.1*	6.7
3.0 m	7.6*	7.6*	5.6*	5.6*	4.3*	4.1	3.1*	3.1	7.1
1.5 m	8.7*	8.7*	6.1*	6.0	4.5*	4.1	3.3*	3.0	7.2
0 m	9.8*	9.8*	6.2*	6.1*	4.5*	4.0	3.5*	3.1	7.0
-1.5 m	10.1*	10.1*	6.4*	6.2	4.1*	3.9	3.2*	3.2*	6.4
-3.0 m	9.4*	9.4*	4.8*	4.8*			4.2*	4.2*	4.8

### TRIPLE ARTICULATION - DIPPERSTICK 2.45 M

#### REAR BLADE UP

Front Side	REACH										
	3.0 m		4.5 m		6.0 m		7.5 m		At max reach		m
7.5 m			3.9*	3.8					3.3*	3.3*	
6.0 m			4.2*	3.9	3.5*	2.4			2.8*	2.2	6.2
4.5 m	4.8*	4.8*	4.6*	3.8	3.6	2.5			2.6*	1.8	7.0
3.0 m	7.5*	6.4	5.3*	3.7	3.6	2.4			2.5	1.6	7.5
1.5 m	8.6*	6.3	5.3	3.6	3.6	2.4	2.4	1.5	2.4	1.5	7.6
0 m	9.6*	6.4	5.3	3.6	3.5	2.2			2.5	1.6	7.3
-1.5 m	10.0*	6.1	5.3	3.3	3.3	2.1			2.8	1.7	6.8
-3.0 m	10.1*	6.0	5.1	3.2					3.5*	2.4	5.4

#### FRONT BLADE+REAR STAB. DOWN

Front Side	REACH										
	3.0 m		4.5 m		6.0 m		7.5 m		At max reach		m
7.5 m			3.9*	3.9*					3.3*	3.3*	
6.0 m			4.2*	4.2*	3.5*	3.5*			2.8*	2.8*	6.2
4.5 m	4.8*	4.8*	4.6*	4.6*	3.9*	3.9*			2.6*	2.6*	7.0
3.0 m	7.5*	7.5*	5.3*	5.3*	4.1*	4.1			2.6*	2.6*	7.5
1.5 m	8.6*	8.6*	6.0*	6.0*	4.4*	4.0	3.2*	2.8	2.7*	2.7*	7.6
0 m	9.6*	9.6*	6.1*	6.0*	4.4*	4.0			3.0*	2.9	7.3
-1.5 m	10.0*	10.0*	6.2*	6.2	4.4*	3.9			3.1*	3.1*	6.8
-3.0 m	10.1*	10.1*	5.6*	5.6*					3.5*	3.5*	5.4

### TRIPLE ARTICULATION - DIPPERSTICK 2.95 M

#### REAR BLADE UP

Front Side	REACH										
	3.0 m		4.5 m		6.0 m		7.5 m		At max reach		m
9.0 m	4.1*	4.1*							4.0*	4.0*	
7.5 m			3.8*	3.8*					2.7*	2.7*	5.5
6.0 m			3.6*	3.6*	3.5*	2.5			2.3*	1.9	6.8
4.5 m			3.9*	3.8	3.6*	2.5	2.4*	1.6	2.2*	1.6	7.6
3.0 m	6.4*	6.4*	5.0*	3.7*	3.6	2.5	2.5	1.6	2.2*	1.4	8.0
1.5 m	8.2*	6.2	5.2	3.5	3.5*	2.4	2.5	1.6	2.2	1.4	8.1
0 m	9.2*	6.2	5.2	3.6	3.5	2.3	2.4	1.5	2.2	1.4	7.9
-1.5 m	9.7*	6.1	5.4	3.4	3.4	2.1			2.4	1.5	7.3
-3.0 m	10.3*	6.0	5.2	3.2	3.3	2.0			2.9*	1.9	6.3

#### FRONT BLADE+REAR STAB. DOWN

Front Side	REACH										
	3.0 m		4.5 m		6.0 m		7.5 m		At max reach		m
9.0 m	4.1*	4.1*							4.0*	4.0*	
7.5 m			3.8*	3.8*					2.7*	2.7*	5.5
6.0 m			3.6*	3.6*	3.5*	3.5*			2.3*	2.3*	6.8
4.5 m			3.9*	3.9*	3.6*	3.6*	2.4*	2.4*	2.2*	2.2*	7.6
3.0 m	6.4*	6.4*	5.0*	5.0*	3.9*	3.9*	3.3*	2.9	2.2*	2.2*	8.0
1.5 m	8.2*	8.2*	5.7*	5.7*	4.2*	4.0*	3.4*	2.9	2.3*	2.3*	8.1
0 m	9.2*	9.2*	6.0*	5.9	4.3*	4.0	3.3*	2.8	2.5*	2.5*	7.9
-1.5 m	9.7*	9.7*	6.1*	6.0*	4.5*	3.9			2.9*	2.9	7.3
-3.0 m	10.3*	10.3*	6.2*	6.1	3.4*	3.4*			2.9*	2.9*	6.3

#### REAR BLADE DOWN

Front Side	REACH										
	3.0 m		4.5 m		6.0 m		At max reach		m		
7.5 m			4.5*	4.3						4.1*	4.1
6.0 m			4.5*	4.3					3.3*	2.8	5.8
4.5 m	6.6*	6.6*	4.9*	4.2	4.1*	2.7	3.1*	2.2	6.7		
3.0 m	7.6*	7.3	5.6*	4.1	4.3*	2.7	3.1*	2.0	7.1		
1.5 m	8.7*	7.2*	6.1*	4.1	4.5*	2.6	3.3*	1.9	7.2		
0 m	9.8*	7.4	6.2*	4.1	4.5*	2.5	3.5*	2.0	7.0		
-1.5 m	10.1*	7.2	6.4*	3.8	4.1*	2.4	3.2*	2.2	6.4		
-3.0 m	9.4*	7.0	4.8*	3.7			4.2*	3.4	4.8		

#### REAR BLADE DOWN

Front Side	REACH										
	3.0 m		4.5 m		6.0 m		7.5 m		At max reach		m
7.5 m			3.9*	3.9*					3.3*	3.3*	
6.0 m			4.2*	4.2*	3.5*	2.7			2.8*	2.5	6.2
4.5 m	4.8*	4.8*	4.6*	4.2	3.9*	2.8			2.6*	2.0	7.0
3.0 m	7.5*	7.3	5.3*	4.1	4.1*	2.8			2.6*	1.8	7.5
1.5 m	8.6*	7.2	6.0*	4.0	4.4*	2.7	3.2*	1.8	2.7*	1.7	7.6
0 m	9.6*	7.2	6.1*	4.1	4.4*	2.5			3.0*	1.8	7.3
-1.5 m	10.0*	7.1	6.2*	3.8	4.4*	2.4			3.1*	2.0	6.8
-3.0 m	10.1*	7.0	5.6*	3.7					3.5*	2.8	5.4

#### REAR BLADE DOWN

Front Side	REACH										
	3.0 m		4.5 m		6.0 m		7.5 m		At max reach		m
9.0 m	4.1*	4.1*							4.0*	4.0*	
7.5 m			3.8*	3.8*					2.7*	2.7*	5.5
6.0 m			3.6*	3.6*	3.5*	2.8			2.3*	2.2	6.8
4.5 m			3.9*	3.9*	3.6*	2.8	2.4*	1.8	2.2*	1.8	7.6
3.0 m	6.4*	6.4*	5.0*	4.1	3.9*	2.7	3.3*	1.8	2.2*	1.6	8.0
1.5 m	8.2*	7.1	5.7*	4.0	4.2*	2.7	3.4*	1.8	2.3*	1.6	8.1
0 m	9.2*	7.1	6.0*	4.0	4.3*	2.6	3.3*	1.7	2.5*	1.6	7.9
-1.5 m	9.7*	7.1	6.1*	3.9	4.5*	2.4			2.9*	1.8	7.3
-3.0 m	10.3*	7.1	6.2*	3.7	3.4*	2.4			2.9*	2.2	6.3

The above loads (kg) are compliant to the ISO standards and refer to the excavator equipped with bucket. The indicated loads are no more than 87% of hydraulic system lift capacity or 75% of static tipping load. Values marked with an asterisk (\*) are limited by the hydraulic lifting capacity rather than the tipping load.



# WHEELED EXCAVATORS

## WX168

## SPECIFICATIONS

### ENGINE

Net engine power (ISO 14396/ECE R120) \_\_\_\_\_ 105 kW / 141 hp  
 Rated \_\_\_\_\_ 2000 rpm  
 Make and model \_\_\_\_\_ F4GE9684F J602  
 Type \_\_\_\_\_ Water-cooled, 6 cylinder direct injection type diesel engine with intercooler turbo-charger  
 Displacement \_\_\_\_\_ 6.7 l  
 Number of cylinders \_\_\_\_\_ 6  
 Bore x stroke \_\_\_\_\_ 104 x 132 mm  
 Maximum torque at 1200 rpm \_\_\_\_\_ 575 Nm

### ELECTRICAL SYSTEM

Voltage \_\_\_\_\_ 24 V  
 Batteries \_\_\_\_\_ 2 x 12 V  
 Battery rating (each) \_\_\_\_\_ 100 Ah  
 Alternator \_\_\_\_\_ 70 A  
 Starter motor \_\_\_\_\_ 4 kW

### TRANSMISSION

	km/h	km/h
Max Road travel speed	20	35
Max Field travel speed	5	8
Creep speed	2.5	2.5

Maximum drawbar pull (field) \_\_\_\_\_ 92 kN  
 Power Shift multi-disc gearbox shiftable under load.  
 Automatic or manual gear shift control.  
 Travel mode automatically engaged by pressing accelerator pedal.

### HYDRAULIC SYSTEM

2 x Primary pumps \_\_\_\_\_ 3 variable displacement, axial piston  
 Total maximum flow \_\_\_\_\_ 360 l/min (2 x 144 + 72)  
 Auxiliary low flow, optional (on/off) \_\_\_\_\_ 22 l/min  
 Auxiliary medium flow, optional (proportional) \_\_\_\_\_ 80 l/min  
 Implement /travel pressure \_\_\_\_\_ 340/370 bar  
 Power Boost \_\_\_\_\_ 370 bar  
 Swing circuit pressure \_\_\_\_\_ 370/390 bar  
 Pilot pump \_\_\_\_\_ 45 bar  
 Boom cylinder mono \_\_\_\_\_ 110 x 1170 mm  
 Boom cylinder 2-piece boom \_\_\_\_\_ 110 x 1020 mm  
 Arm cylinder \_\_\_\_\_ 115 x 1290 mm  
 Bucket cylinder \_\_\_\_\_ 100 x 1025 mm

Positioning cylinder \_\_\_\_\_ 155 x 745 mm  
 Cylinder end stroke damping.  
 Electrohydraulic servo-control.  
 Three-pump hydraulics with two main pumps and separate swing pump. 8 selectable power stages with permanent Power Boost in lift stages:  
 Low idle, Lift 1, Lift 2, Eco 1, Eco 2, Eco 3, Heavy, Roadtravel  
 Adjustable swing acceleration (power) and deceleration (brake)  
 Automatic power increase in the drive mode.

### SWING DRIVE

Swing speed \_\_\_\_\_ 8,6 rpm  
 Swing torque (SAE J1371) \_\_\_\_\_ 42,4 kNm  
 The swing function is operated by a hydraulic closed circuit coupled with a mechanical reducer integrating an automatic static brake.  
 The hydro-static swing brake is adjustable in 3 settings.

### BRAKES

Service brakes: play free, oil bath multi disc type integrated in all four wheel hubs.  
 Work brake: acts on service brakes and locks front axle oscillation.  
 Parking brake: spring type mechanical acting on the transmission.  
 Emergency brake: double braking circuit and automatic parking and brake actuation with the engine shut down.

### STEERING

Type \_\_\_\_\_ ORBITROL with safety valve  
 Pump \_\_\_\_\_ gear type  
 Steering cylinder \_\_\_\_\_ double effect, integrated in axle

### TYRES

Twin tyres \_\_\_\_\_ 10.00-20/80-22.5  
 Single tyres \_\_\_\_\_ 18R 19.5, 600/40-22.5  
 Tyre availability can be limited by local homologation.

### CAPACITIES

Engine oil \_\_\_\_\_ 15 l  
 Cooling system \_\_\_\_\_ 22 l  
 Fuel tank \_\_\_\_\_ 274 l  
 Hydraulic system (incl. tank) \_\_\_\_\_ 215 l for mono  
 \_\_\_\_\_ 230 l for triple articulation



# GENERAL DIMENSIONS

## WX168

equipped with twin tires 10.00 - 20

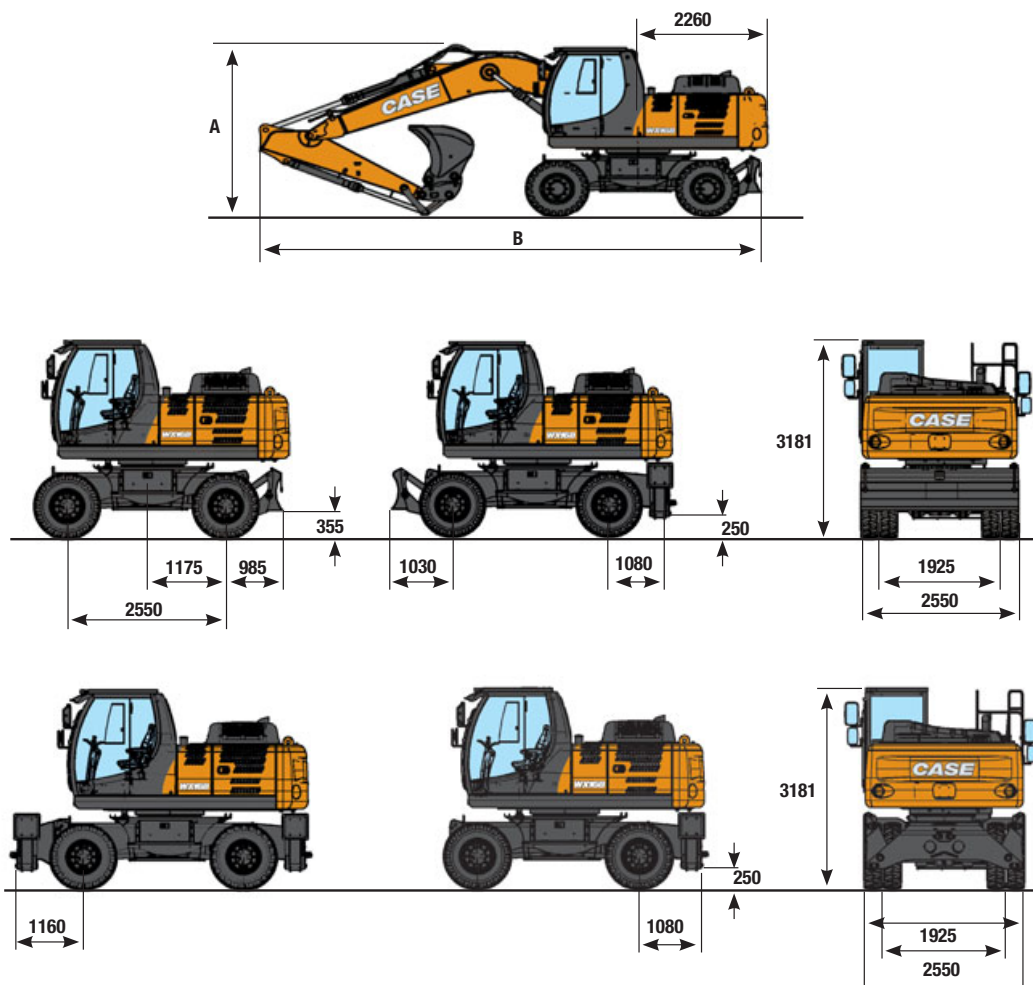

### TRIPLE ARTICULATION 5.15 m

### MONOBOOM 4.75 m

	Arm 2.20 m	Arm 2.60 m	Arm 3.10 m	Arm 2.20 m	Arm 2.60 m	Arm 3.10 m
A	2870 mm	2825 mm	3315 mm	3110 mm	3075 mm	3730 mm
B with rear blade	8670 mm	8600 mm	8585 mm	8635 mm	8575 mm	8575 mm
B with rear stabilizers	8730 mm	8660 mm	8645 mm	8695 mm	8635 mm	8635 mm

## OPERATING WEIGHT WX168

2,55 axle width include bucket 480 kg and quick coupler 250 kg (with 10.00-20)

	TRIPLE ARTICULATION			MONOBOOM		
	Arm 2.20 m	Arm 2.60 m	Arm 3.10 m	Arm 2.20 m	Arm 2.60 m	Arm 3.10 m
Rear blade	17100 kg	17150 kg	17220 kg	16950 kg	17000 kg	17070 kg
Stabilizers	17400 kg	17450 kg	17520 kg	17250 kg	17300 kg	17370 kg
Blade and stabilizers	18000 kg	18050 kg	18120 kg	17850 kg	17900 kg	17970 kg
Stabilizers rear and front	18400 kg	18450 kg	18520 kg	18250 kg	18300 kg	18370 kg



# PERFORMANCE DATA

## WX168

### TRIPLE ARTICULATION

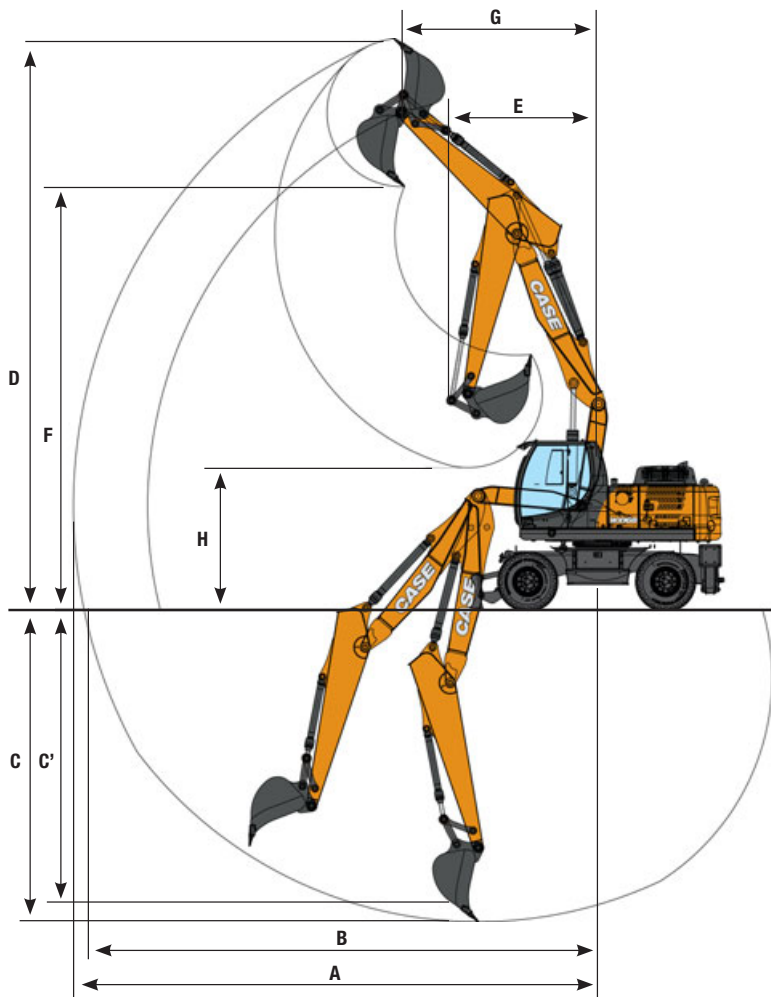

### MONOBOOM

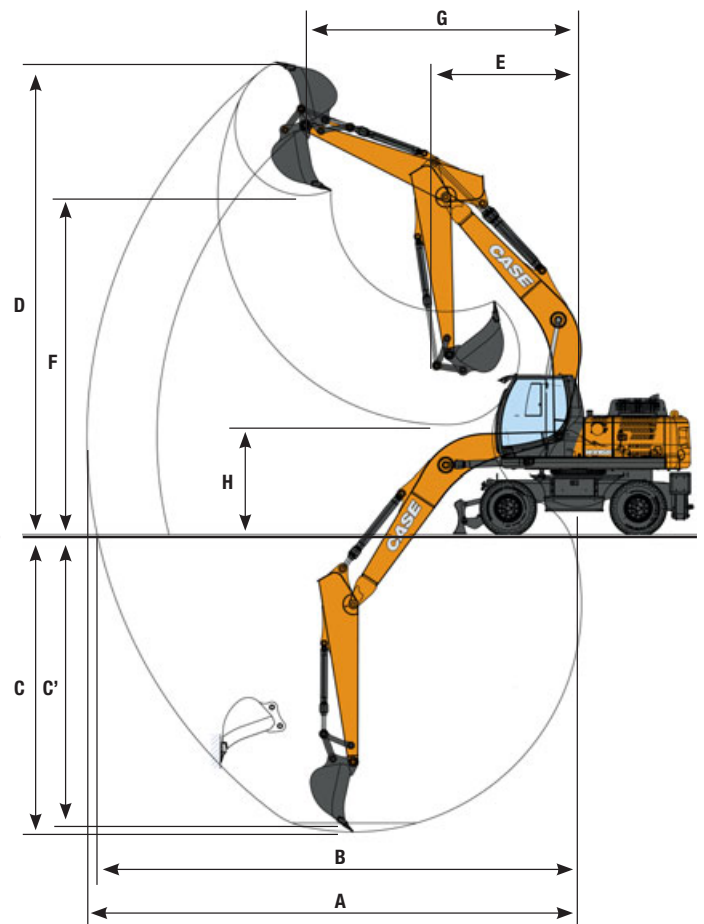

	TRIPLE ARTICULATION			MONOBOOM		
	Arm 2.20 m	Arm 2.60 m	Arm 3.10 m	Arm 2.20 m	Arm 2.60 m	Arm 3.10 m
A Max. digging reach	8950 mm	9290 mm	9780 mm	8840 mm	9150 mm	9630 mm
B Max. digging reach at ground level	8730 mm	9080 mm	9580 mm	8620 mm	8940 mm	9430 mm
C Max. digging depth	4910 mm	5290 mm	5790 mm	4940 mm	5330 mm	5840 mm
C' Max. depth of cut for 8° level bottom	4800 mm	5180 mm	5690 mm	4710 mm	5120 mm	5660 mm
D Max. digging height	9970 mm	10190 mm	10580 mm	8900 mm	8980 mm	9270 mm
E Min. front swing radius	3060 mm	2810 mm	2870 mm	3340 mm	2950 mm	2860 mm
F Max. loading height	7220 mm	7450 mm	7840 mm	6280 mm	6370 mm	6650 mm
G Front swing radius at max height	3060 mm	3400 mm	3710 mm	4540 mm	4930 mm	4540 mm
H Max. loading height (arm retracted)	3660 mm	3130 mm	2630 mm	3070 mm	2640 mm	2140 mm

### DIGGING FORCE - ISO WX168

	Arm 2.20 m	Arm 2.60 m	Arm 3.10 m
Arm digging force	83 kN	70 kN	61 kN
- with auto power boost	90 kN	76 kN	67 kN
Bucket digging force	113 kN	113 kN	113 kN
- with auto power boost	123 kN	123 kN	123 kN

# LIFTING CAPACITY

## WX168

### MONO BOOM - DIPPERSTICK 2.20 M

#### REAR BLADE UP

Front Side	REACH										
	3.0 m		4.5 m		6.0 m		At max reach		m		
	⊥	↔	⊥	↔	⊥	↔	⊥	↔	⊥	↔	
7.5 m									4.6*	4.1	4.7
6.0 m					4.1	2.7	4.0	2.6	3.2	2.1	7.0
4.5 m			6.4	4.1	4.0	2.6	3.2	2.1	3.2	2.1	7.0
3.0 m			5.9	3.7	3.9	2.5	2.8	1.8	3.2	2.1	7.0
1.5 m			5.6	3.4	3.7	2.3	2.7	1.7	3.2	2.1	7.0
0 m			5.4	3.3	3.6	2.2	2.8	1.8	3.2	2.1	7.0
-1.5 m	9.3*	6.0	5.4	3.3	3.6	2.2	2.2	3.2	2.0	6.6	
-3.0 m	9.1*	6.2	5.5	3.4				4.1	2.6	5.5	

#### FRONT BLADE+REAR STAB. DOWN

Front Side	REACH										
	3.0 m		4.5 m		6.0 m		At max reach		m		
	⊥	↔	⊥	↔	⊥	↔	⊥	↔	⊥	↔	
7.5 m					4.7*	4.7*	4.6*	4.6*	4.7		
6.0 m					4.7*	4.7*	4.2*	4.2*	6.1		
4.5 m			6.6*	6.6*	5.5*	4.6	4.1*	3.7	7.0		
3.0 m			8.0*	6.9	6.1*	4.5	4.3*	3.3	7.4		
1.5 m			9.1*	6.5	6.6*	4.3	4.7*	3.1	7.5		
0 m			9.3*	6.4	6.7*	4.2	5.4*	3.3	7.2		
-1.5 m	9.3*	9.3*	8.6*	6.4	6.3*	4.2	5.5*	3.7	6.6		
-3.0 m	9.1*	9.1*	6.8*	6.5			5.2*	4.8	5.5		

### MONO BOOM - DIPPERSTICK 2.60 M

#### REAR BLADE UP

Front Side	REACH											
	3.0 m		4.5 m		6.0 m		7.5 m		At max reach		m	
	⊥	↔	⊥	↔	⊥	↔	⊥	↔	⊥	↔	⊥	↔
7.5 m									3.3*	3.3*	5.2	
6.0 m					4.1*	2.8			3.0*	2.4	6.5	
4.5 m			6.1*	4.2	4.1	2.7			3.0*	1.9	7.3	
3.0 m			6.0	3.8	3.9	2.5	2.8	1.8	2.7	1.7	7.7	
1.5 m			5.6	3.5	3.7	2.4	2.7	1.7	2.6	1.6	7.8	
0 m	5.0*	5.0*	5.4	3.3	3.6	2.2	2.6	1.7	2.6	1.6	7.5	
-1.5 m	8.7*	5.9	5.4	3.2	3.6	2.2			2.9	1.8	7.0	
-3.0 m	10.2*	6.1	5.5	3.3					3.7	2.3	6.0	

#### FRONT BLADE+REAR STAB. DOWN

Front Side	REACH											
	3.0 m		4.5 m		6.0 m		7.5 m		At max reach		m	
	⊥	↔	⊥	↔	⊥	↔	⊥	↔	⊥	↔	⊥	↔
7.5 m					4.1*	4.1*			3.3*	3.3*	5.2	
6.0 m					4.1*	4.1*			3.0*	3.0*	6.5	
4.5 m			6.1*	6.1*	5.2*	4.7			3.0*	3.0*	7.3	
3.0 m			7.6*	7.0	5.8*	4.5	3.9*	3.2	3.1*	3.1	7.7	
1.5 m			8.8*	6.6	6.4*	4.3	4.8*	3.1	3.4*	3.0	7.7	
0 m	5.0*	5.0*	9.3*	6.4	6.7*	4.2	4.3*	3.1	3.9*	3.0	7.5	
-1.5 m	8.7*	8.7*	8.8*	6.3	6.5*	4.1			5.0*	3.4	7.0	
-3.0 m	10.2*	10.2*	7.4*	6.4					5.2*	4.3	6.0	

### MONO BOOM - DIPPERSTICK 3.10 m

#### REAR BLADE UP

Front Side	REACH											
	3.0 m		4.5 m		6.0 m		7.5 m		At max reach		m	
	⊥	↔	⊥	↔	⊥	↔	⊥	↔	⊥	↔	⊥	↔
7.5 m									2.4*	2.4*	5.9	
6.0 m					3.7*	2.8			2.2*	2.1	7.1	
4.5 m					4.1	2.7	2.8	1.8	2.2*	1.7	7.8	
3.0 m	10.9*	7.0	6.1	3.9	3.9	2.5	2.8	1.8	2.3*	1.5	8.2	
1.5 m			5.7	3.5	3.7	2.3	2.7	1.7	2.3	1.4	8.3	
0 m	5.2*	5.2*	5.4	3.2	3.6	2.2	2.6	1.6	2.3	1.5	8.0	
-1.5 m	7.8*	5.7	5.3	3.2	3.5	2.1	2.6	1.6	2.6	1.6	7.5	
-3.0 m	10.7	5.9	5.3	3.2	3.5	2.2			3.1	1.9	6.6	
-4.5 m			5.4*	3.4					5.2*	3.2	4.6	

#### FRONT BLADE+REAR STAB. DOWN

Front Side	REACH											
	3.0 m		4.5 m		6.0 m		7.5 m		At max reach		m	
	⊥	↔	⊥	↔	⊥	↔	⊥	↔	⊥	↔	⊥	↔
7.5 m					3.7*	3.7*			2.4*	2.4*	5.9	
6.0 m					4.4*	4.4*	3.0*	3.0*	2.2*	2.2*	7.1	
4.5 m					4.4*	4.4*	3.0*	3.0*	2.2*	2.2*	7.8	
3.0 m	10.9*	10.9*	6.9*	6.9*	5.5*	4.5	4.0*	3.2	2.3*	2.3*	8.2	
1.5 m			8.4*	6.6	6.1*	4.3	5.0*	3.1	2.5*	2.5*	8.3	
0 m	5.2*	5.2*	9.1*	6.3	6.6*	4.1	5.1*	3.0	2.8*	2.7	8.0	
-1.5 m	7.8*	7.8*	9.0*	6.3	6.5*	4.1	3.5*	3.0	3.5*	3.0	7.5	
-3.0 m	11.4*	11.4*	7.9*	6.3	5.7*	4.1			4.9*	3.6	6.6	
-4.5 m			5.4*	5.4*					5.2*	5.2*	4.6	

The above loads (kg) are compliant to the ISO standards and refer to the excavator equipped with bucket. The indicated loads are no more than 87% of hydraulic system lift capacity or 75% of static tipping load. Values marked with an asterisk (\*) are limited by the hydraulic lifting capacity rather than the tipping load.

#### REAR BLADE DOWN

Front Side	REACH											
	3.0 m		4.5 m		6.0 m		At max reach		m			
	⊥	↔	⊥	↔	⊥	↔	⊥	↔	⊥	↔		
7.5 m									4.6*	4.6	4.7	
6.0 m					4.7*	3.1	4.2*	3.0	6.1			
4.5 m			6.6*	4.7	5.5*	3.0	4.1*	2.4	7.0			
3.0 m			8.0*	4.3	6.1*	2.8	4.3*	2.1	7.4			
1.5 m			9.1*	3.9	6.2	2.7	4.4	2.0	7.5			
0 m			9.3*	3.8	6.1	2.6	4.6	2.0	7.2			
-1.5 m	9.3*	7.1	8.6*	3.8	6.1	2.6	5.3	2.3	6.6			
-3.0 m	9.1*	7.3	6.8*	3.9			5.2*	3.0	5.5			

#### FRONT+REAR STAB. DOWN

Front Side	REACH										
	3.0 m		4.5 m		6.0 m		At max reach		m		
	⊥	↔	⊥	↔	⊥	↔	⊥	↔	⊥	↔	
7.5 m					4.7*	4.7*	4.6*	4.6*	4.7		
6.0 m					4.7*	4.7*	4.2*	4.2*	6.1		
4.5 m			6.6*	6.6*	5.5*	5.5*	4.1*	4.1*	7.0		
3.0 m			8.0*	8.0*	6.1*	5.5	4.3*	4.0	7.4		
1.5 m			9.1*	8.3	6.6*	5.3	4.7*	3.9	7.5		
0 m			9.3*	8.1	6.7*	5.2	5.4*	4.0	7.2		
-1.5 m	9.3*	9.3*	8.6*	8.1	6.3*	5.2	5.5*	4.5	6.6		
-3.0 m	9.1*	9.1*	6.8*	6.8*			5.2*	5.2*	5.5		

#### REAR BLADE DOWN

Front Side	REACH											
	3.0 m		4.5 m		6.0 m		7.5 m		At max reach		m	
	⊥	↔	⊥	↔	⊥	↔	⊥	↔	⊥	↔	⊥	↔
7.5 m					4.1*	3.1			3.3*	3.3*	5.2	
6.0 m					4.1*	3.1			3.0*	3.0*	6.5	
4.5 m			6.1*	4.8	5.2*	3.0			3.0*	3.0*	7.3	
3.0 m			7.6*	4.4	5.8*	2.9	3.9*	2.0	3.1*	1.9	7.7	
1.5 m			8.8*	4.0	6.2	2.7	4.4	2.0	3.4*	1.9	7.8	
0 m	5.0*	5.0*	9.3*	3.8	6.1	2.6	4.3*	1.9	3.9*	1.9	7.5	
-1.5 m	8.7*	7.0	8.8*	3.8	6.1	2.5			4.8	2.1	7.0	
-3.0 m	10.2*	7.2	7.4*	3.8					5.2*	2.6	6.0	

#### FRONT+REAR STAB. DOWN

Front Side	REACH											
	3.0 m		4.5 m		6.0 m		7.5 m		At max reach		m	
	⊥	↔	⊥	↔	⊥	↔	⊥	↔	⊥	↔	⊥	↔
7.5 m					4.1*	4.1*			3.3*	3.3*	5.2	
6.0 m					4.1*	4.1*			3.0*	3.0*	6.5	
4.5 m			6.1*	6.1*	5.2*	5.2*			3.0*	3.0*	7.3	
3.0 m			7.6*	7.6*	5.8*	5.5	3.9*	3.9	3.1*	3.1*	7.7	
1.5 m			8.8*	8.3	6.4*	5.3	4.8*	3.8	3.4*	3.4*	7.8	
0 m	5.0*	5.0*	9.3*	8.1	6.7*	5.2	4.3*	3.8	3.9*	3.7	7.5	
-1.5 m	8.7*	8.7*	8.8*	8.1	6.5*	5.1			5.0*	4.2	7.0	
-3.0 m	10.2*	10.2*	7.4*	7.4*					5.2*	5.2*	6.0	

#### REAR BLADE DOWN

Front Side	REACH											
	3.0 m		4.5 m		6.0 m		7.5 m		At max reach		m	
	⊥	↔	⊥	↔	⊥	↔	⊥	↔	⊥	↔	⊥	↔
7.5 m					3.7*	3.2			2.4*	2.4*	5.9	
6.0 m					4.4*	3.1	3.0*	2.1	2.2*	2.2*	7.1	
4.5 m					4.4*	3.1	3.0*	2.1	2.2*	2.2*	7.8	
3.0 m	10.9*	8.2	6.9*	4.4	5.5*	2.9	4.0*	2.0	2.3*	1.7	8.2	
1.5 m			8.4*	4.0	6.1*	2.7	4.4	1.9	2.5*	1.7	8.3	
0 m	5.2*	5.2*	9.1*	3.8	6.1	2.5	4.3	1.9	2.8*	1.7	8.0	
-1.5 m	7.8*	6.8	9.0*	3.7	6.0	2.5	3.5*	1.8	3.5*	1.8	7.5	
-3.0 m	11.4*	7.0	7.9*	3.7	5.7*	2.5			4.9*	2.2	6.6	
-4.5 m												





www.casece.com

**EXPERTS FOR THE REAL WORLD**  
**SINCE 1842**

**CASE**  
CONSTRUCTION



Form No. 20170GB - Printed in Italy - MediaCross Firenze - 01/17

**CNH INDUSTRIAL  
DEUTSCHLAND GMBH**  
Case Baumaschinen  
Benzstr. 1-3 - D-74076 Heilbronn  
DEUTSCHLAND

**CNH INDUSTRIAL FRANCE, S.A.**  
16-18 Rue des Rochettes  
91150 Morigny-Champigny  
FRANCE

**CNH INDUSTRIAL - UK**  
First Floor, Barclay Court 2,  
Heavens Walk,  
Doncaster - DN4 5HZ  
UNITED KINGDOM

**CNH INDUSTRIAL - SOUTH AFRICA**  
Waterfall Business Park  
Bekker Street, Howick Close  
1685 Midrand - Johannesburg  
REPUBLIC OF SOUTH AFRICA

**CNH INDUSTRIAL  
MAQUINARIA SPAIN, S.A.**  
Avda. José Gárate, 11  
28823 Coslada (Madrid)  
ESPAÑA

**CNH INDUSTRIAL ITALIA SPA**  
Strada di Settimo, 323  
10099 San Mauro Torinese (TO)  
ITALIA

**CASE CUSTOMER CENTRE  
PARIS**  
RN 330 - Penchard  
77122 - Monthyon  
FRANCE

**CNH INDUSTRIAL - MIDDLE EAST**  
DAFZA - Dubai Airport Free Zone  
West Wing 4 B, Office 642  
P.O. Box 54588, Dubai,  
UNITED ARAB EMIRATES

**NOTE:** Standard and optional fittings can vary according to the demands and specific regulations of each country. The illustrations may include optional rather than standard fittings - consult your Case dealer. Furthermore, CNH Industrial reserves the right to modify machine specifications without incurring any obligation relating to such changes.

Conforms to directive 2006/42/EC

**CASE**  
**00800-2273-7373**

The call is free from a land line.  
Check in advance with your Mobile Operator if you will be charged. Toll free number not available from all calling areas.