

M-SERIES CRAWLER DOZERS
1150M | 1650M | 2050M

CASE
CONSTRUCTION



TECHNOLOGY
THAT PAYS

www.casece.com
EXPERTS FOR THE REAL WORLD
SINCE 1842

M-SERIES CRAWLER DOZERS



EXPERTS FOR THE REAL WORLD SINCE 1842

- 1842** CASE is founded.
- 1946** Allis-Chalmers is the first manufacturer to introduce a torque converter on dozers. In the 30s they had invented permanently lubricated track rollers and sealed and lubricated tracks.
- 1951** First CASE dozer made in cooperation with ATC and promoted under Terratrack brand.
- 1956** CASE acquires ATC and is the first manufacturer to introduce tracks counterrotation on the 1000 Series Terratrack dozer.

HERITAGE

A TRADITION OF INDUSTRY FIRSTS



- 1974** *FIAT acquires Allis-Chalmers and in the 70s introduces the exclusive “Equistatic” geometry on bulldozer machines. In the late 90s CASE launches its exclusive “CASE Extended Life Track” undercarriage.*
- 2008** *CASE introduces the “Dual Path” hydrostatic transmission on the “K” series.*
- 2013** *CASE is the first to introduce SCR technology on the “M” series dozer.*
- 2015** *CASE extends its European product line-up with the new grader range.*
- 2017** *CASE renews its dozer range introducing a completely re-engineered undercarriage and “ULTRA-LIFE” tracks.*

M-SERIES CRAWLER DOZERS



LOW EMISSIONS

Premium Tier 4 technology

The state-of-the-art common rail engine delivers top performance in load response, max torque, power and fuel economy.

The combustion is optimised for maximum efficiency: it occurs at high temperatures and uses 100% fresh, cool air, as the air intake is separated from the exhaust. The turbocharged engine with an Air-to-Air intercooler relies on well proven multi injection technology to maximize torque back-up and fuel efficiency with reduced engine noise and vibrations.

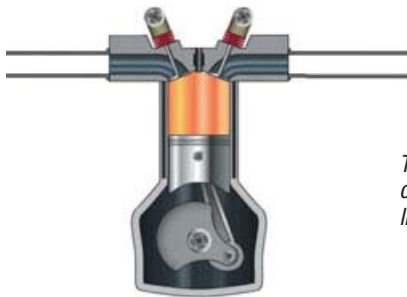

The high temperature combustion produces a very limited amount of particulates



AdBlue is sprayed in the exhaust in order to eliminate NOx through Catalytic Reduction (SCR)

Tier 4 interim

With SCR the engine runs with optimised efficiency. The M Series engine can run with 20% biodiesel, reducing even further its environmental impact. When the tractive effort grows and the rpm tends to drop, the engine power rises by up to 16% to 1800 rpm. The result: constant performance and higher pulling capacity. In addition, the ability to work with high torque at lower engine rpm reduces engine wear.



SUPERIOR COOLING EFFICIENCY

Fresh air breathing engine

The cooling package of the 1650M and 2050M has been redesigned and fitted with a hydrostatic reversible fan. In the new design, the radiators are mounted with no overlap, so that each radiator receives fresh air, maintaining constant fluid temperatures. The hydrostatic fan continuously adapts its speed to match the real cooling demand, reducing power absorption. The reversing mode reduces maintenance needs and lengthens cleaning intervals.

ENGINE AND TRANSMISSION DRAWBAR PULL LEADERSHIP



HIGH RELIABILITY

"ULTRA-LIFE" tracks

The redesigned undercarriage ensures higher stress resistance, and combines optimized dozer balancing for enhanced stability and controllability.

The exclusive "ULTRA-LIFE" technology with lubricated bushing extends chain and undercarriage life in toughest conditions and sensibly reduces the dozer noise level.

Considering that 50% of dozer maintenance costs are due to undercarriage components, the CASE solution brings a clear benefit for the most demanding customers.

M-SERIES CRAWLER DOZERS



VERSATILE CONTROLS

Agile and strong

The operator has full control of the massive power of the M Series dozer. The electrohydraulic joystick enables them to customise the reversing and steering sensitivity for faster and more efficient cycles. The decelerator pedal can be set to reduce either travel speed only or both travel and engine speed.

Automatic blade functions

The advanced electronics functions enable the operator to control specific functions in addition to the standard blade movements:

- the on-board computer can be set directly from the joystick;
- the blade reaction can be set choosing from 3 levels of sensitivity;
- the grading button immediately reduces the speed of the blade by 50% for more accurate soil contour;
- the shaking mode enables the operator to shed material quickly, especially when working with sticky soil.



HIGH VISIBILITY

Drive your performance forward!

The M series cab is engineered for operator performance, comfort and safety. The new positioning, further forward on the machine, ensures complete blade visibility. The operator can work with confidence and more productively in every operation. The air suspended seat is easy to adjust, providing every operator with a perfect working position. The powerful air conditioning system combined with the best-in-class noise level provide an excellent working environment, reducing operator stress during long working days.

CUSTOMIZABLE CONTROLS

PRODUCTIVITY BOOSTING ELECTRONICS

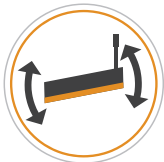

BLADE CONTROL SET UP

Flexible performance

The M series is ready to work with the most common blade controls available on the market. The machine can be prepared in the factory for a specific configuration, ensuring perfect wire layout, visibility and component integration, guaranteeing the high standards of reliability of every CASE product are maintained.



HIGH VERSATILITY

Tools for every task

A wide offering of implements and equipments can be installed on the new CASE dozer:

- Drawbar • 3 shanks parallel ripper
- Front cab protections and grids • Winches predisposition

A choice of blades are available for optimum dozing performance:

- PAT • Foldable PAT (reduces the transport width within 3 m) • Straight • Semi-U

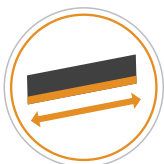

BULLDOZER “EQUISTATIC” GEOMETRY

Balanced pushing effort

All the Bulldozer units offer the patented «Equistatic» system that increases the tilting capability, while reducing the efforts on the pushbeams, increasing the overall frame reliability and reducing the overall wear of components.

QUICK GROUND ACCESS FOR SERVICING



SAFE AND EASY MAINTENANCE

Ground access for servicing

The hydrostatic transmission brings less complexity and lower maintenance requirements than a traditional one. Belly plates on the bottom of the machine provide excellent access to controls and transmission components.

The final drive installation on the main dozer frame enables dismounting while leaving the hydrostatic components in place. The transmission can even be reached through the cab floor, so it can be serviced directly on the jobsite.

The refueling points (Fuel/Ad Blue/Hydraulic Oil) are conveniently placed on the rear of the cab in a well-protected place. The daily maintenance can be done quickly thanks to dedicated steps that make the access easier and safer.

The new single piece main frame enables you to service the main controls easily from the ground, simply opening the wide lateral shieldings.

Oil levels, battery status, electric components, filters and the emergency cut off switches are rationally grouped and clearly identified with colour coding. With the M Series, you can quickly get ready for your working day.





THE SCIENCE BIT

The CASE SiteWatch telematics system uses a high-tech control unit mounted on each machine to collate information from that machine and from GPS satellites. This data is then sent wirelessly through the mobile communication networks to the CASE Telematics Web Portal.



SiteWatch: centralised fleet control benefits at your fingertips

Measure your true asset availability and optimise it

- Eliminate the “phantom fleet”: SiteWatch allows to identify spare units or under loaded machines on each site.
- Become able to reallocate units where they are more needed.
- Forward Maintenance Planning is easier since the actualised working hours are always available.
- Extend the benefits of SiteWatch to the rest of your fleet: SiteWatch can be installed on the units of other brands as well.

Challenge your Total Cost of Ownership!

- Being able to compare the fuel usage of different machine types will allow you choose the right equipment.
- Save on transport costs with planned and grouped maintenance tasks.
- Peace of mind, optimised uptime and lower repair costs: with preventive maintenance you can for example be alerted if the engine needs to be serviced and avoid a disruptive breakdown.
- Be able to compare your asset Return On Investment on different sites.
- Your equipment is used only during working hours. You can set up alerts so that you know if it is in use during the weekend or at night.
- Integrate with the programmed maintenance package, so that you can be sure every machine is at the right place at the right time.

More Safety, Lower Insurance Premium

- Keep thieves away: dissuade them from attacking your asset because it is geo-localised. SiteWatch is hidden so that thieves can't find it quickly.
- Your fleet is used only where you decide. You can define a virtual fence and receive an email when a machine exits that perimeter.

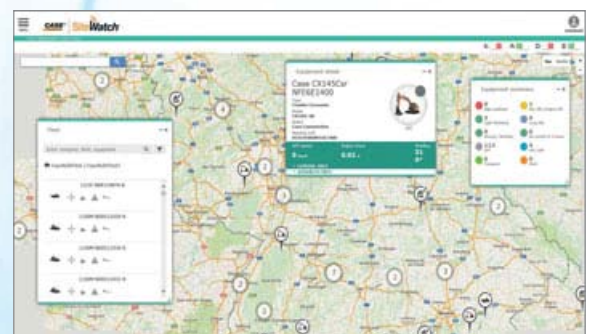

MAIN REASONS TO CHOOSE THE M-SERIES



LOW EMISSIONS

- The only dozer with SCR in the market: exceptional efficiency and fuel savings, no losses due to extra cooling needs.



EASY MAINTENANCE

- The functional groups are located beside the cab for quick intervention.
- The transmission components can be checked directly under the cab floor.

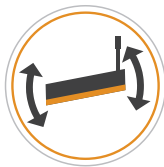

BLADE CONTROL SET UP

- Leading brands plug and play blade control system.



HIGH VERSATILITY

- The wide variety of options and bulldozers offers every customer the possibility of creating a machine tailored for the most demanding applications in different environments.



VERSATILE CONTROLS

- Electronically controlled fast material drop from the blade in sticky conditions. All the main working parameters can be set to satisfy customer requirements.





HIGH VISIBILITY

- The cab, positioned 100 mm forward, ensures best-in-class visibility on the blade corner as well as better bulldozer weight distribution.



SUPERIOR COOLING EFFICIENCY

- Double cooling surface and no overlapping of radiators. The reversible fan keeps the exchanging area clean and dramatically extends service intervals.



BULLDOZER "EQUISTATIC" GEOMETRY

- Emphasizes blade tilting while compensating twisting effort on the push beams device.



HIGH RELIABILITY

- CASE "ULTRA-LIFE" tracks dramatically reduces the cost of ownership by 50%. Noise level is also reduced for best-in-class comfort



M-SERIES

CRAWLER DOZERS

1150M SPECIFICATIONS

ENGINE

Model	FPT F4HFE613F*A002
Cylinders	6
Displacement	6.7 l
Fuel injection	Direct
Fuel filter	Spin-on w/ in-line strainer
Air intake	Cross-flow
Cooling	Liquid
Engine speeds	RPM
High idle – no load	2200 +/- 50
Rated – full load	2200
Low idle	1100 +/- 25
Horsepower SAE J1349:	
Engine rated net power	127 hp - 95 kW @2200 rpm
Engine max net power	138 hp - 103 kW @2200 rpm
Engine peak power	151 hp-113 kW @1800 rpm
Rated net torque	610 Nm
Max net torque	632 Nm

Engine lubrication

Pump	Deep sump plate cooler w/ pressurized under-piston nozzles
------	--

Pump operating angle ratings:

Side-to-side	35°
Fore and aft	45°

Radiator:

Core size area (Water Radiator)	0.32 m ²
Rows of tubes	25

Fan

Diameter	660 mm
Ratio	0,96:1

POWERTRAIN

Dual path hydrostatic

Pump	Variable axial piston
Motor	Variable bent axis piston
Max. drawbar pull*	213.5 kN
Transmission	Single lever control electronic straight tracking
Oil filter	2 micron, spin-on, replaceable
Travel speeds*	
Forward	0 – 9.3 km/h
Reverse	0 – 9.3 km/h
Parking brakes	Heavy-duty, spring-applied, hydraulic pressure release
Steering brakes	Hydrostatic
Final drive	2 helical gear reduction to planetary output
Ratio	61.4:1

TRANSMISSION COOLING

Type	Oil to air
Core size	0.18 m ²

ELECTRICAL SYSTEM

Alternator	120 amps
Batteries (2)	12-volt, low-maintenance 925 cold-cranking amps @ -18°C

OPERATOR ENVIRONMENT

ROPS/FOPS cab; Pneumatically suspended seat; Seat belt; Adjustable armrests; Foot rests; Tool storage area; Headliner; Floor mat; Mirror; Noise level 79dbA.

Warning lights:

Air filter; Alternator; Diagnostic fault indicator; Engine coolant temperature; Engine oil pressure; Hydraulic filter; Low fuel level; Park brake engaged; Service soon indicator; Transmission filter; Transmission charge pressure.

Gauges:

Ad Blue Level; Battery voltage; Digital hourmeter/tachometer diagnostic/service reminder; Fuel level; Transmission oil temperature; Transmission speed indicator; Water temperature.

Audible warnings:

Engine coolant temperature; Engine oil pressure; Low fuel level, Transmission charge pressure; Transmission/hydraulic temperature; Rear wiper for cab; Internal mirror; Radio.

HYDRAULICS

Pump flow @ 2200 RPM	138.5 l/min
Max pressure	195 bar
Lift cylinder™	nr. 2
Bore diameter	108 mm
Rod diameter	50.8 mm
Stroke	488 mm
Angle cylinder	nr. 2
Bore diameter	114.3 mm
Rod diameter	63.5 mm
Stroke	465.7 mm
Tilt cylinder	nr. 1
Bore diameter	127 mm
Rod diameter	63.5 mm
Stroke	148.3 mm

SERVICE CAPACITY

Fuel tank	322 l
Ad Blue tank	52 l
Engine oil w/ filter	16.4 l
Engine oil w/o filter	15.6 l
Engine cooling system	28 l
Hydraulic reservoir	193 l
Final drive (per side)	15 l
Track rollers (ea)	0.25 l
Front idlers (ea)	0.33 l
Carrier rollers – each	0.25 l

UNDERCARRIAGE

Track adjustment	Hydraulic
Frame	Oscillating equalizer beam suspension and pivot shaft
Track link pitch	175 mm
Track shoe height	55 mm
Pin diameter	36.58 mm
Bushing diameter	
"Heavy-Duty" track	62 mm
"Max-Life" track	79 mm
Track shoes per side	43
Track rollers per side	7
Carrier rollers per side	2
Track roller rail diameter	203 mm
Track on ground	
Shoe area	
559 mm	29050 cm ²
660 mm	34323 cm ²
762 mm	39627 cm ²

PAT BLADE

Variable blade pitch	55° +/- 5°
Lift speed – per second	503 mm
Cutting edge	Reversible, replaceable
Width	203.2 mm
Thickness	19.1 mm

RIPPER

Max. penetration	499 mm
Width	1711 mm
Cut	1635 mm
Max. ground clearance	403 mm
Max. number of shanks	3
Tooth spacing	
w/3 teeth	785 mm
Hydraulic cylinder	Double-acting
Diameter	102 mm
Stroke	254 mm
Rod	50.8 mm

OPERATING WEIGHT

Operating weight includes cab, full fuel and hydraulic tanks, 170 lb (77 kg) operator, "Heavy-Duty" chain, front pull hook, rear retrieval hitch, track guides, back up alarm, horn, lights, track shoe, C-frame and blade width as noted.

	Weight (kg)	Add-on weights	Weight (kg)	"Max-Life" chains	Weight (kg)
Long Track	14122	Drawbar	66	22" (560 mm)	2320
Wide Track	14594	Ripper (3 shank)	1078	26" (660 mm)	2542
Low Ground Pressure	14804	Front counterweight	430	30" (760 mm)	2766
				Full Rock Guard	281
				Sweeps	63

TRACK AND SHOE OPTIONS

LT (Long Tracks)

560 mm	closed grousers and "Heavy-Duty"
560 mm	open grousers and "Max-Life"

WT (Wide Tracks)

560 mm	closed grousers and "Heavy-Duty"
560 mm	open grousers and "Max-Life"
660 mm	closed grousers and "Heavy-Duty"
660 mm	open grousers and "Max-Life"

LGP (Low Ground Pressure)

760 mm	closed grousers and "Heavy-Duty"
760 mm	open grousers and "Max-Life"

M-SERIES CRAWLER DOZERS

1150M GENERAL DIMENSIONS

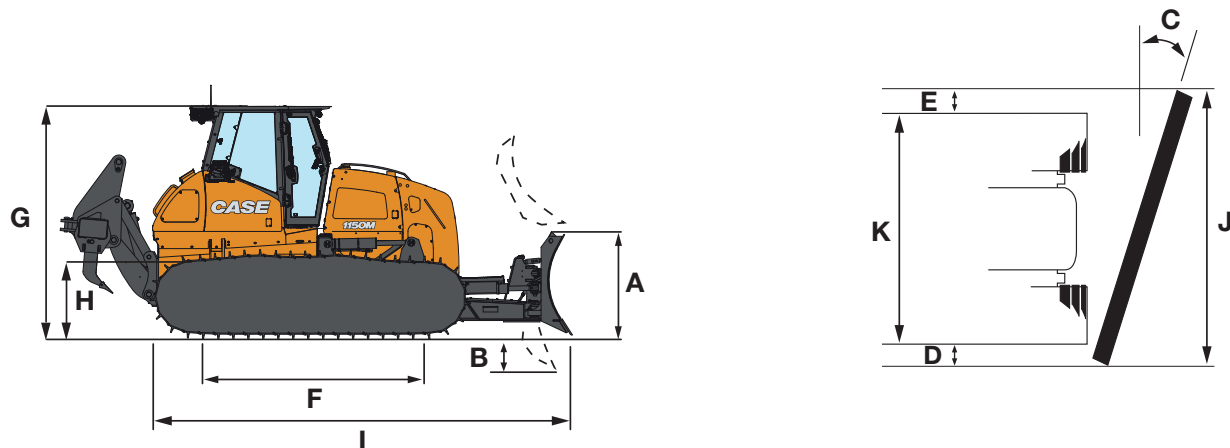

Line drawings are for illustrative purpose only and may not be exact representation of unit.

	LT (Long Track)	WT (Wide Track)	LGP (Low Ground Pressure)
BLADES			
Blade width	3048 mm		3353 mm
SAE blade capacity	2.88 m ³		3.18 m ³
A Blade height		1120 mm	
Blade lift above ground		926 mm	
B Blade depth below ground		518 mm	
C Blade angle both directions		25°	
Blade tilt, each end (up to 8.3°)	430 mm		450 mm
D Cast reach track coverage	408 mm	419 mm	317 mm
E Cut reach track coverage	20 mm	31 mm	-71 mm
TRACKS			
Track gauge	1829 mm		2032 mm
Max shoe width	560 mm	660 mm	760 mm
F Track on ground		2600 mm	
Area of track on ground	2.90 m ²	3.43 m ²	3.96 m ²
Ground pressure	0.47 kg/cm ² *	0.41 kg/cm ² **	0.36 kg/cm ² ***
DIMENSIONS			
G Height to top of cab		2956 mm	
H Ground clearance		322 mm	
I Length			
- Blade straight with drawbar		5088 mm	
- Blade straight with ripper		6191 mm	
Width			
- Blade straight	3048 mm		3355 mm
J Blade angled	2819 mm		3111 mm
K Over track	2388 mm	2692 mm	2794 mm

*with 560 mm shoes

** with 660 mm shoes

***with 760 mm shoes

NOTE: Ground clearance and overall height dimensions are with the grousers fully penetrated. Add 52.5 mm if unit is on solid surface.

SPECIFICATIONS



M-SERIES

CRAWLER DOZERS

1650M SPECIFICATIONS

ENGINE

Model	FPT F4HFE6132*A004
Cylinders	6
Displacement	6.7 l
Fuel injection	Direct common rail
Fuel filter	Spin-on w/ in-line strainer
Air intake	Cross-flow
Cooling	Liquid
Engine speeds	RPM
High idle – no load	2200 +/- 50
Rated – full load	2200
Low idle	800 +/- 25
Horsepower SAE J1349:	
Engine rated net power	150 hp - 112 kW @ 2200 rpm
Engine max net power	164 hp - 122 kW @ 2200 rpm
Engine Peak Power	173 hp - 129 kW @ 1800 rpm
Rated net torque	666 Nm
Max net torque	726 Nm

Engine lubrication

Pump _____ Deep sump plate cooler w/ pressurized under-piston nozzles

Pump operating angle ratings:

Side-to-side _____ 35°

Fore and aft _____ 45°

Radiator:

Core size area (Water Radiator) _____ 0.33 m²

Rows of tubes _____ 4

Fan

Diameter _____ 700 mm

Ratio _____ hydraulically driven

POWERTRAIN

Dual path hydrostatic

Pump _____ Variable axial piston

Motor _____ Variable bent axis piston

Max. drawbar pull* _____ 272 kN

Transmission _____ Single lever control electronic straight tracking

Oil filter _____ 2 micron, spin-on, replaceable

Travel speeds*

Forward _____ 0 – 9.3 km/h

Reverse _____ 0 – 9.3 km/h

Parking brakes _____ Heavy-duty, spring-applied, hydraulic pressure release

Steering brakes _____ Hydrostatic

Final drive _____ 2 helical gear reduction to planetary output

Ratio _____ 61.4:1

TRANSMISSION COOLING

Type _____ Oil to air

Core size _____ 0.31m²

ELECTRICAL SYSTEM

Alternator _____ 120 amps

Batteries (2) _____ 12-volt, low-maintenance
925 cold-cranking amps @ -18°C

OPERATOR ENVIRONMENT

ROPS/FOPS cab; Pneumatically suspended seat; w/ back adjustment; Seat belt; Adjustable armrests; Foot rests; Tool storage area; Headliner; Floor mat; Tilting seat platform; Noise Level 75 dbA.

Warning lights:

Air filter; Alternator; Diagnostic fault indicator; Engine coolant temperature; Engine oil pressure; Hydraulic filter; Low fuel level; Park brake engaged; Service soon indicator; Transmission filter; Transmission charge pressure.

Gauges:

Battery voltage; Digital hourmeter/tachometer diagnostic/service reminder; Fuel level; Transmission oil temperature; Transmission speed indicator; Water temperature.

Audible warnings:

Engine coolant temperature; Engine oil pressure; Low fuel level, Transmission charge pressure; Transmission/hydraulic temperature.

HYDRAULICS

Pump flow @ 2200 RPM _____ 149 l/min

Max pressure _____ 206 bar

Lift Cylinder PAT _____ nr. 2

Bore diameter _____ 114.3 mm

Rod diameter _____ 63.5 mm

Stroke _____ 428 mm

Angle cylinder PAT _____ nr. 2

Bore diameter _____ 114.3 mm

Rod diameter _____ 63.5 mm

Stroke _____ 502.7 mm

Tilt cylinder PAT _____ nr. 1

Bore diameter _____ 127 mm

Rod diameter _____ 63.5 mm

Stroke _____ 148.3 mm

Lift cylinder Bull Dozer

Bore diameter _____ 95.3 mm

Rod diameter _____ 57.2 mm

Stroke _____ 906 mm

Tilt cylinder Bull Dozer

Bore diameter _____ 114.3 mm

Rod diameter _____ 63.5 mm

Stroke _____ 98.9 mm

SPECIFICATIONS

SERVICE CAPACITY

Fuel tank	322 l
AD Blue Tank	52 l
Engine oil w/ filter	16.4 l
Engine oil w/o filter	15.6 l
Engine cooling system	32 l
Hydraulic reservoir	160 l
Final drive - per side	15 l
Track rollers - each	0.25 l
Front idlers - each	0.33 l
Carrier rollers - each	0.27 l

UNDERCARRIAGE

Track adjustment	Hydraulic
Frame	Oscillating equalizer beam suspension and pivot shaft
Track link pitch	
"Heavy-Duty" track	190 mm
"Ultra-Life" track	190 mm
Track shoe height	56 mm
Pin diameter	38 mm
Bushing diameter	
"Heavy-Duty" track	65 mm
"Ultra-Life" Track	86 mm
Track shoes per side	45
Track rollers per side	8
Carrier rollers per side	2
Track roller rail diameter	203 mm

TRACK ON GROUND

Shoe area	
560 mm	34509 cm ²
610 mm	37650 cm ²
710 mm	43892 cm ²
820 mm	50128 cm ²
860 mm	53338 cm ²

PAT BLADE

Variable blade pitch - adjustable	55° +/- 5°
Lift speed - per second	483 mm
Cutting edge	Reversible, replaceable
Width	200 mm
Thickness	20 mm

RIPPER

Max. penetration	545 mm
Width	1953 mm
Cut width	1889 mm
Max. ground clearance	611 mm
Max. number of shanks	3
Tooth spacing	
w/3 teeth	944 mm
Hydraulic cylinder	Double-acting
Diameter	155 mm
Stroke	596 mm
Rod	69 mm

OPERATING WEIGHT

Operating weight includes cab, full fuel and hydraulic tanks, 170 lb (77 kg) operator, "Heavy-Duty" chain, front pull hook, rear retrieval hitch, track guides, back up alarm, horn, lights, track shoe, C-frame and blade width as noted.

	Weight (kg)	Add-on weights	Weight (kg)	"Ultra-Life" Chains	Weight (kg)
Extra Long Track	17123 kg PAT	Drawbar	66	22" (560 mm)	2942
	18030 kg Semi-U	Ripper (3 shank)	1749	24" (610 mm)	3060
Wide Track	17531 kg PAT	Winch	1057	28" (710 mm)	3334
				32" (820 mm)	3596
Low Ground Pressure	17940 kg PAT			34" (860 mm)	3714
				Full Rock Guard	189
				Sweeps	63

M-SERIES

CRAWLER DOZERS

1650M TRACK AND SHOE OPTIONS

XLT (Extra Long Tracks)

560 mm	closed grousers and "Heavy-Duty"
560 mm	open grousers and "Ultra-Life"
610 mm	closed grousers and "Heavy-Duty"
610 mm	open grousers and "Ultra-Life"

WT (Wide Tracks)

710 mm	closed grousers and "Heavy-Duty"
710 mm	open grousers and "Ultra-Life"
820 mm	closed grousers and "Heavy-Duty"
820 mm	open grousers and "Ultra-Life"

LGP (Low Ground Pressure)

860 mm	closed grousers and "Heavy-Duty"
860 mm	open grousers and "Ultra-Life"

BLADE DIMENSIONS	Bull Dozer Semi-U	Straight PAT	Straight PAT	Foldable PAT
Blade Capacity SAE J1265	4.84 m ³	3.27 m ³	3.99 m ³	4.04 m ³
Undercarriage available	XLT		WT-LGP	
J Blade width	3359 mm	3302 mm	3974 mm	
Blade width in transport position	3359 mm	3000 mm	3609 mm	3039 mm
A Blade height	1319 mm		1176 mm	
Max. Tilt	+/- 410 mm	+/- 450 mm	+/- 550 mm	
Max. Pitch	+/-2.5°			
C Max. Angle	-		+/- 28°	
B Digging depth.	572 mm		503 mm	
Max lift above ground	1124 mm		1077 mm	
D Cast reach track coverage	434 mm	457 mm	559 mm	509 mm
E Cut reach track coverage	434 mm	53 mm	149 mm	99 mm

1650M GENERAL DIMENSIONS

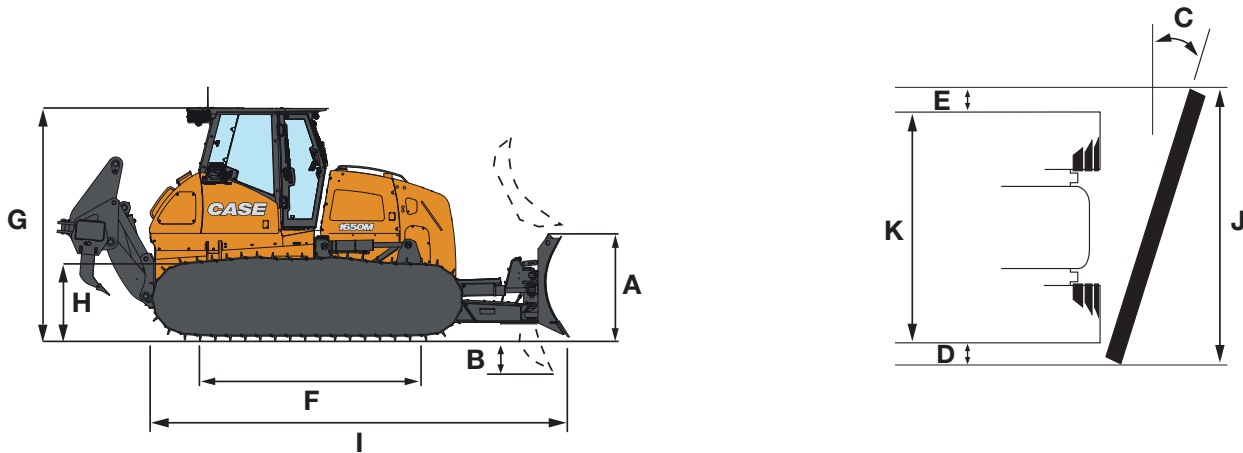

Line drawings are for illustrative purpose only and may not be exact representation of unit.

	XLT (Extra Long Track)	WT (Wide Track)	LGP (Low Ground Pressure)
TRACKS			
Track gauge	1930 mm		2184 mm
Max shoe width	610 mm	820 mm	860 mm
F Track on ground		3087 mm	
Area of track on ground	3.76 m ²	5.01 m ²	5.33 m ²
Ground pressure	0.45 kg/cm ² *	0.36 kg/cm ² **	0.33 kg/cm ² ***
DIMENSIONS			
G Height to top of cab		2971 mm	
H Ground clearance		342 mm	
I Length			
- Blade straight with drawbar	5678 mm PAT 5985 mm Semi-U	5678 mm	5678 mm
- Blade straight with ripper	7038 mm PAT 7345 mm Semi-U		7038 mm
Width			
- Blade straight	3302 mm PAT 3332 mm Semi-U		3974 mm PAT
J Blade angled	3000 mm PAT		3609 mm PAT 3039 mm PAT Foldable
K Over track	2490 mm with 560 mm shoes	2994 mm with 820 mm shoes	3039 mm with 860 mm shoes

* with 610 mm shoes and PAT blade
 ** with 710 mm shoes and PAT blade
 *** with 860 mm shoes and PAT blade

NOTE: Ground clearance and overall height dimensions are with the grousers fully penetrated. Add 52.5 mm if unit is on solid surface.

M-SERIES

CRAWLER DOZERS

2050M SPECIFICATIONS

ENGINE

Model _____ FPT F4FHE613J*A017
 Cylinders _____ 6
 Displacement _____ 6.7 l
 Fuel injection _____ Direct common rail
 Fuel filter _____ Spin-on w/ in-line strainer
 Air intake _____ Cross-flow
 Cooling _____ Liquid
 Engine speeds _____ RPM
 High idle – no load _____ 2200 +/- 50
 Rated – full load _____ 2200
 Low idle _____ 800 +/- 25
 Horsepower SAE J1349:
 Engine rated net power _____ 214 hp - 160 kW @ 2200 rpm
 Engine max net power _____ 232 hp - 173 kW @ 2200 rpm
 Engine Peak Power _____ 246 hp-184 kW @ 1800 rpm
 Rated net torque _____ 1004 Nm
 Max net torque _____ 1082 Nm

Engine lubrication

Pump _____ Deep sump plate cooler w/ pressurized under-piston nozzles

Pump operating angle ratings:

Side-to-side _____ 35°

Fore and aft _____ 45°

Radiator:

Core size area (Water Radiator) _____ 0.33 m²

Rows of tubes _____ 4

Fan

Diameter _____ 700 mm

Ratio _____ hydraulically driven

POWERTRAIN

Dual path hydrostatic

Pump _____ Variable axial piston

Motor _____ Variable bent axis piston

Max. drawbar pull* _____ 360 kN

Transmission _____ Single lever control electronic straight tracking

Oil filter _____ 2 micron, spin-on, replaceable

Travel speeds*

Forward _____ 0 – 9.8 km/h

Reverse _____ 0 – 9.8 km/h

Parking brakes _____ Heavy-duty, spring-applied, hydraulic pressure release

Steering brakes _____ Hydrostatic

Final drive _____ 2 helical gear reduction to planetary output

Ratio _____ 48.75 :1

TRANSMISSION COOLING

Type _____ Oil to air

Core size _____ 0.31m²

ELECTRICAL SYSTEM

Alternator _____ 120 amps

Batteries (2) _____ 12-volt, low-maintenance
 1200 cold-cranking amps @ -18°C

OPERATOR ENVIRONMENT

ROPS/FOPS cab; Pneumatically suspended seat; w/ back adjustment; Seat belt; Adjustable armrests; Foot rests; Tool storage area; Headliner; Floor mat; Tilting seat platform; Noise level 77.2dba.

Warning lights:

Air filter; Alternator; Diagnostic fault indicator; Engine coolant temperature; Engine oil pressure; Hydraulic filter; Low fuel level; Park brake engaged; Service soon indicator; Transmission filter; Transmission charge pressure.

Gauges:

Battery voltage; Digital hourmeter/tachometer diagnostic/service reminder; Fuel level; Transmission oil temperature; Transmission speed indicator; Water temperature.

Audible warnings:

Engine coolant temperature; Engine oil pressure; Low fuel level, Transmission charge pressure; Transmission/hydraulic temperature.

HYDRAULICS

Pump flow @ 2200 RPM _____ 179.5 l/min

Max pressure _____ 248 bar

Lift Cylinder PAT _____ nr. 2

Bore diameter _____ 114.3 mm

Rod diameter _____ 63.5 mm

Stroke _____ 428 mm

Angle cylinder PAT _____ nr. 2

Bore diameter _____ 114.3 mm

Rod diameter _____ 63.5 mm

Stroke _____ 502.7 mm

Tilt cylinder PAT _____ nr. 1

Bore diameter _____ 127 mm

Rod diameter _____ 63.5 mm

Stroke _____ 148.3 mm

Lift cylinder Bull Dozer

Bore diameter _____ 88.9 mm

Rod diameter _____ 57.2 mm

Stroke _____ 1074 mm

Tilt cylinder Bull Dozer

Bore diameter _____ 114.3 mm

Rod diameter _____ 63.5 mm

Stroke _____ 98.9 mm

SPECIFICATIONS

SERVICE CAPACITY

Fuel tank	405 l
AD Blue Tank	62 l
Engine oil w/ filter	16.4 l
Engine oil w/o filter	15.6 l
Engine cooling system	38 l
Hydraulic reservoir	210 l
Final drive - per side	25 l
Track rollers - each	0.35 l
Front idlers - each	0.33 l
Carrier rollers - each	0.31 l

UNDERCARRIAGE

Track adjustment _____ Hydraulic
 Frame _____ Oscillating equalizer beam suspension and pivot shaft

Track link pitch

"Heavy-Duty" track	203 mm
"Ultra-Life" track	203 mm
Track shoe height	71.5 mm
Pin diameter	44.5 mm

Bushing diameter

"Heavy-Duty" track	72 mm
"Ultra-Life" track	93 mm
Track shoes per side	40 LT 45 XLT /WT/LGP

Track rollers per side

LT	7
XLT/WT-LGP	8
Carrier rollers per side	2
Track roller rail diameter	227 mm

TRACK ON GROUND

Shoe area	
610 mm	33782 cm ² LT
	39608 cm ² XLT
710 mm	46158 cm ² WT
760 mm	49468 cm ² WT
910 mm	59337 cm ² LGP

PAT BLADE

Variable blade pitch - adjustable	55° +/- 5°
Lift speed - per second	483 mm
Cutting edge	Reversible, replaceable
Width	200 mm
Thickness	20 mm

RIPPER

Max. penetration	491 mm
Width	1953 mm
Cut width	1889 mm
Max. ground clearance	577 mm
Max. number of shanks	3
Tooth spacing	
w/3 teeth	944 mm
Hydraulic cylinder	Double-acting
Diameter	155 mm
Stroke	596 mm
Rod	69 mm

OPERATING WEIGHT

Operating weight includes cab, full fuel and hydraulic tanks, 170 lb (77 kg) operator, "Heavy-Duty" chain, front pull hook, rear retrieval hitch, track guides, back up alarm, horn, lights, track shoe, C-frame and blade width as noted.

	Weight (kg)	Add-on weights	Weight (kg)	"Ultra-Life" chains	Weight (kg)
Long Track	20213 kg PAT	Drawbar	66	24" (610 mm)	3536
	20206 kg Straight	Ripper (3 shank)	1933	28" (710 mm)	4324
	20336 kg Semi-U	Winch	1057	30" (760 mm)	4498
Extra Long Tracks	20599 kg PAT			36" (910 mm)	5018
	20592 kg Straight			Center rockguard	
	20722 kg Semi-U			LT	221
Wide Tracks	21269 kg PAT			XLT/WT/LGP	306
	21971 kg PAT Foldable			Sweeps	63
	21431 kg Straight				
Low Ground Pressure	22115 kg PAT				
	22790 kg PAT Foldable				
	22131 kg Straight				

M-SERIES

CRAWLER DOZERS

2050M TRACK AND SHOE OPTIONS

LT (Long Tracks)

610 mm	closed grousers and "Heavy-Duty"
610 mm	open grousers and "Ultra-Life"

XLT (Extra Long Tracks)

610 mm	closed grousers and "Heavy-Duty"
610 mm	open grousers and "Ultra-Life"

WT (Wide Tracks)

710 mm	closed grousers and "Heavy-Duty"
710 mm	open grousers and "Ultra-Life"
760 mm	closed grousers and "Heavy-Duty"
760 mm	open grousers and "Ultra-Life"

LGP (Low Ground Pressure)

910 mm	closed grousers and "Heavy-Duty"
910 mm	open grousers and "Ultra-Life"

BLADE DIMENSIONS	Bull Dozer Straight	Bull Dozer Straight	Bull Dozer Semi-U	Straight PAT	Straight PAT	Foldable PAT
Blade Capacity SAE J1265	3.22 m ³	3.78 m ³	5.57 m ³	4.83 m ³	5.44 m ³	5.54 m ³
Undercarriage available	LT -XLT	WT - LGP	LT-XLT	WT-LGP		
J Blade width	3334 mm	3901 mm	3426 mm	3606 mm	4001 mm	4064 mm
Blade width in transport position	3334 mm	3901 mm	3426 mm	3276 mm	3690 mm	3157 mm
A Blade height	1108 mm		1425 mm	1369 mm		
Max. Tilt	+/-400 mm			+/- 450 mm	+/- 550 mm	
Max. Pitch	+/- 5°				+/- 2.5 °	
C Max. Angle	-				+/- 28°	
B Digging depth.	507 mm	508 mm	547 mm	487 mm		
Max lift above ground	1177 mm		1233 mm	1112 mm		
D Cast reach track coverage	397 mm	367 mm	442 mm	582 mm	477 mm	545 mm
E Cut reach track coverage	397 mm	367 mm	442 mm	148 mm	42 mm	110 mm

2050M GENERAL DIMENSIONS

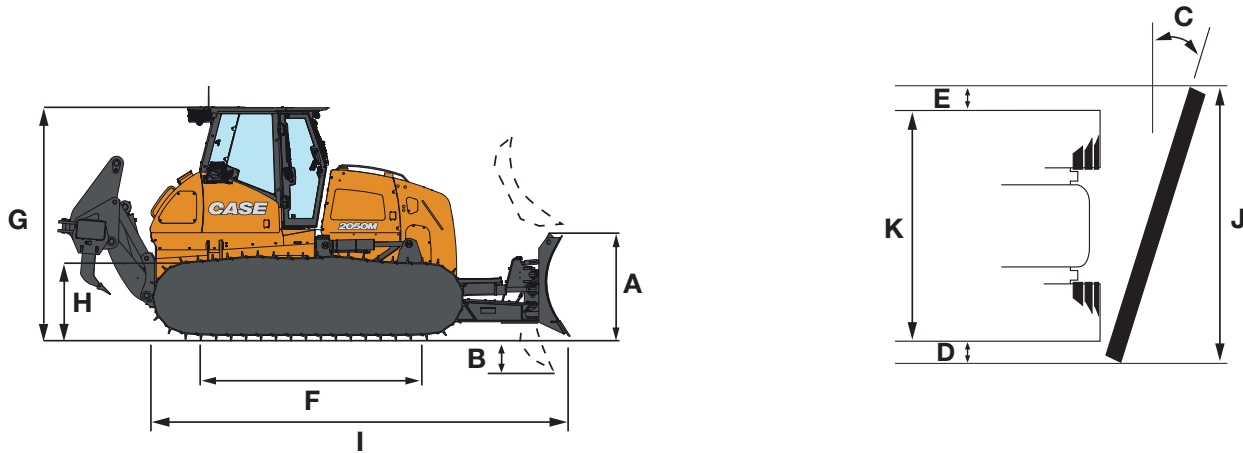

Line drawings are for illustrative purpose only and may not be exact representation of unit.

	LT (Long Track)	XLT (Extra Long Track)	WT (Wide Track)	LGP (Low Ground Pressure)
TRACKS				
Track gauge	1940 mm		2261 mm	
Max shoe width	610 mm		760 mm	910 mm
F Track on ground	2769 mm		3246 mm	
Area of track on ground	3.33 m ²	3.96 m ²	4.99 m ²	5.93 m ²
Ground pressure	0.58 kg/cm ^{2*}	0.44 kg/cm ^{2**}	0.42 kg/cm ^{2***}	0.36 kg/cm ^{2****}
DIMENSIONS				
G Height to top of cab			3150 mm	
H Ground clearance			408 mm	
I Length				
- Blade straight with drawbar	5556 mm PAT 5464 mm Straight Semi-U		5964 mm PAT 5980 mm Straight	
- Blade straight with ripper	6929 mm PAT 6837 mm Straight Semi-U		7337 mm PAT 7353 mm Straight	
Width				
- Blade straight	3606 mm PAT 3334 mm Straight 3426 mm Semi-U		4064 mm PAT PAT Foldable 3900 mm Straight	
J Blade angled	3276 mm PAT		3690 mm PAT 3157 mm PAT Foldable	
K Over track	2540 mm with 610 mm shoes		3011 mm with 760 mm shoes	3176 mm with 910 mm shoes

* with 610 mm shoes and PAT blade
 ** with 710 mm shoes and PAT blade
 *** with 760 mm shoes and PAT blade
 **** with 910 mm shoes and PAT blade

NOTE: Ground clearance and overall height dimensions are with the grousers fully penetrated. Add 52.5 mm if unit is on solid surface.

www.casece.com

EXPERTS FOR THE REAL WORLD
SINCE 1842

CASE
CONSTRUCTION



Form No. 201556B - MediaCross Firenze - 02/17

**CNH INDUSTRIAL
DEUTSCHLAND GMBH**
Case Baumaschinen
Benzstr. 1-3 - D-74076 Heilbronn
DEUTSCHLAND

CNH INDUSTRIAL FRANCE, S.A.
16-18 Rue des Rochettes
91150 Morigny-Champigny
FRANCE

CNH INDUSTRIAL - UK
First Floor, Barclay Court 2,
Heavens Walk,
Doncaster - DN4 5HZ
UNITED KINGDOM

CNH INDUSTRIAL - SOUTH AFRICA
Waterfall Business Park
Bekker Street, Howick Close
1685 Midrand - Johannesburg
REPUBLIC OF SOUTH AFRICA

**CNH INDUSTRIAL
MAQUINARIA SPAIN, S.A.**
Avda. José Gárate, 11
28823 Coslada (Madrid)
ESPAÑA

CNH INDUSTRIAL ITALIA SPA
Strada di Settimo, 323
10099 San Mauro Torinese (TO)
ITALIA

**CASE CUSTOMER CENTRE
PARIS**
RN 330 - Penchard
77122 - Monthyon
FRANCE

CNH INDUSTRIAL - MIDDLE EAST
DAFZA - Dubai Airport Free Zone
West Wing 4 B, Office 642
P.O. Box 54588, Dubai,
UNITED ARAB EMIRATES

NOTE: Standard and optional fittings can vary according to the demands and specific regulations of each country. The illustrations may include optional rather than standard fittings - consult your Case dealer. Furthermore, CNH Industrial reserves the right to modify machine specifications without incurring any obligation relating to such changes.

Conforms to directive 2006/42/EC

CASE
00800-2273-7373

The call is free from a land line.
Check in advance with your Mobile Operator if you will be charged. Toll free number not available from all calling areas.